

## Wiser Home Controller™



5200PG

The Wiser Home Controller gives the homeowner the ability to control lighting, climate, security, blinds, curtains and multi-room audio, while offering the ability to view cameras. All of this can be done locally or remotely.

### Wiser Controller

The Wiser Controller has been purposely built on an edge-router platform that enables the installer to configure the product as a Local Area Network (LAN) and Wide Area Network (WAN) device. This means that it can form the boundary of the home network and offers the opportunity for Wiser to be accessed from both within the home network and remotely through the Internet. There are several configuration scenarios allowing for most existing home network layouts. The Wiser includes a wireless (Wi-Fi) Access Point that supports 802.11 B/G/N with security.

Installers benefit from the all-inclusive platform that includes the edge router and a C-Bus Network Interface (CNI) and busbar that enables ease of cabling and the use of a single power supply. The installer can load the controller configuration through the wireless connection, and can also program the C-Bus Network through the Wiser Controller. If a broadband Internet connection is present,

it is possible to perform these functions remotely. Remote connection is restricted by security policies configured in the Wiser Home Controller, with varying access levels for users and installers.

### Inline C-Bus Network Interface

A new inline design of the C-Bus Network Interface (CNI) is provided as part of the Wiser Home Controller package. The industrial design of the CNI matches the look of the Wiser Controller. The Controller and CNI share a common power supply fed through a custom busbar. The CNI has an RJ45 connection for the Ethernet connection and a screw terminal connection for C-Bus. The screw terminal allows for multiple C-Bus cables to be terminated into the CNI while ensuring that there is no confusion between the C-Bus and Ethernet connections. The CNI also backs up the system clock in the event of C-Bus power failure.

## System Programming

The Wiser Home Controller is programmed using the free Clipsal Piced software. During configuration of graphical user interface (GUI) pages, widgets (pre-formed icons with built-in functionality) are selected and placed into location and function groups. The groups are then applied to backgrounds known as skins for a consistent look and feel across all projects. This consistent user interface is applied for the many available control devices such as web tablets, PDAs, mobile phones and even selected media centres.

The Wiser Home Controller includes an onboard web server, capable of serving up the user interface via a compatible web browser, as well as a version of the GUI that runs on the local PC to help reduce bandwidth. Regardless of whether it is accessed locally, (on the LAN) or remotely (via the Internet), security employs a username and password.

From a tools page, the GUI also provides a link to the setup of Wiser's more technical settings. The Wiser Home Controller also offers a user interface, using a Projector plug-in. Projector is a standalone executable file that can be run on a PC that runs Adobe Flash. Instead of sending all the graphical images across the Internet, they are sourced from the machine running the Projector. This assists where a slow Internet connection is used to access Wiser, as well as reducing the amount of traffic.

## System Features

The Wiser system architecture provides the ideal platform for supporting some of the most sought after features in the automation market. With Ethernet and Internet capabilities, Wiser offers features not previously available in C-Bus devices. Wiser utilises Real Time Protocol (RTP) to synchronise the Wiser's on-board clock (and in turn, the C-Bus network clock on devices such as DLTs) with the time pulled from the Internet. This eliminates 'time drift' and ensures the time is always accurate even with daylight-savings adjustments. This ensures any time-based events, such as schedules, take place when expected. Wiser also includes an on-board web server, email and RSS feed clients as well as supporting both dynamic and static IP addressing. Wiser also supports a dynamic DNS client for popular DNS services.

## Key Features

- Connects directly to the C-Bus network using a C-Bus UTP connection through the Inline CNI.
- Has a convenient form factor.
- Can be used as a gateway to program C-Bus locally or remotely (via an Internet connection).
- Is capable of issuing commands, as well as running schedules and scenes, to a C-Bus network.
- Contains a full C-Bus logic engine.
- Is capable of generating a C-Bus system clock for communication data.
- Incorporates a C-Bus PC Interface (within the CNI).
- Includes C-Bus network connection via the Inline CNI.
- Is programmed using Piced programming software.
- Supports applications including lighting, climate, blinds/curtains, multi-room audio, security and surveillance control.
- Includes pre-configured screens (skins) along with pre-developed graphical user interfaces (GUIs).
- Includes preconfigured 'widgets' to provide graphical components that display and control the state of devices.
- Includes an email client for checking a POP3 non-secure email account.
- Includes an RSS feed client for displaying up to five different RSS feeds, such as weather, news, stocks, etc.
- Supports web camera surveillance for up to six local cameras.
- User interface (UI) can be viewed in a web browser, in Vista Media Centre or using a standalone Flash Projector file.
- Supports Real Time Protocol (RTP) for accurate real time date/time retrieved from the Internet.
- Can be used as a router along with, or place of, existing network equipment.

Part Number and Description	
5200PG	Clipsal Wisier Home Controller complete with C-Bus Network Interface (CNI), busbar, Ethernet lead and power supply.

Programming Specifications	
Maximum number of C-Bus applications supported	10
Maximum number of C-Bus group addresses supported	255 group addresses on each application (2550 total)
Number of programming commands available	>200
Maximum number of If-Then conditions	No specific limit, > 1000
Maximum levels of If-Then 'nesting'	No specific limit, > 1000
Maximum number of individual modules in a program	50
Number of flags	No specific limit, > 1000
Number of variables	No specific limit, > 1000
Number of timers	20 inbuilt, >1000 user definable
Maximum number of event schedules	250
Variable mathematical functions	Yes
Schedule events by time	Yes
Sunrise/Sunset events	Yes
Daylight savings time adjustment	Yes
Random time events	Yes
Power failure recovery process	255 group addresses
Time resolution	1 second
Clock accuracy	1 min/month (1 sec/1000 yrs with NTP)
RSS feed display	Up to 5 feeds
Email client	POP3 unsecure, 1 email account, email qty, sender and subject

Electrical and Mechanical Specifications - Wisier Controller	
Connections	1 x WAN RJ45 socket  4 x LAN RJ45 sockets (1 is used for the CNI connection)  1 socket for 12V d.c. power supply
Wireless	802.11 B/G/N
Operating ambient temperature	0-45 degrees C
Operating relative humidity	10-90%, non-condensing

Electrical and Mechanical Specifications - Inline CNI	
Connections	1 x LAN RJ45 socket  1 x Screw terminal block (under cover for C-Bus twisted pair connection)  1 socket for 5-24V d.c. power supply (100mA @ 12V)

Graphical User Interface (GUI)	
Platform	Requirements
PC or Web Tablet running Windows XP®, Vista® or Linux®	Web browser running Adobe® Flash® V9 or above
Nokia mobile phone	Symbian S60 mobile phone, 320x256 (portrait) or 256x320 (landscape), with Flash Lite 2.1 or 3.0 with XML Socket Support
Windows® Vista® Media Centre	Via installable application module

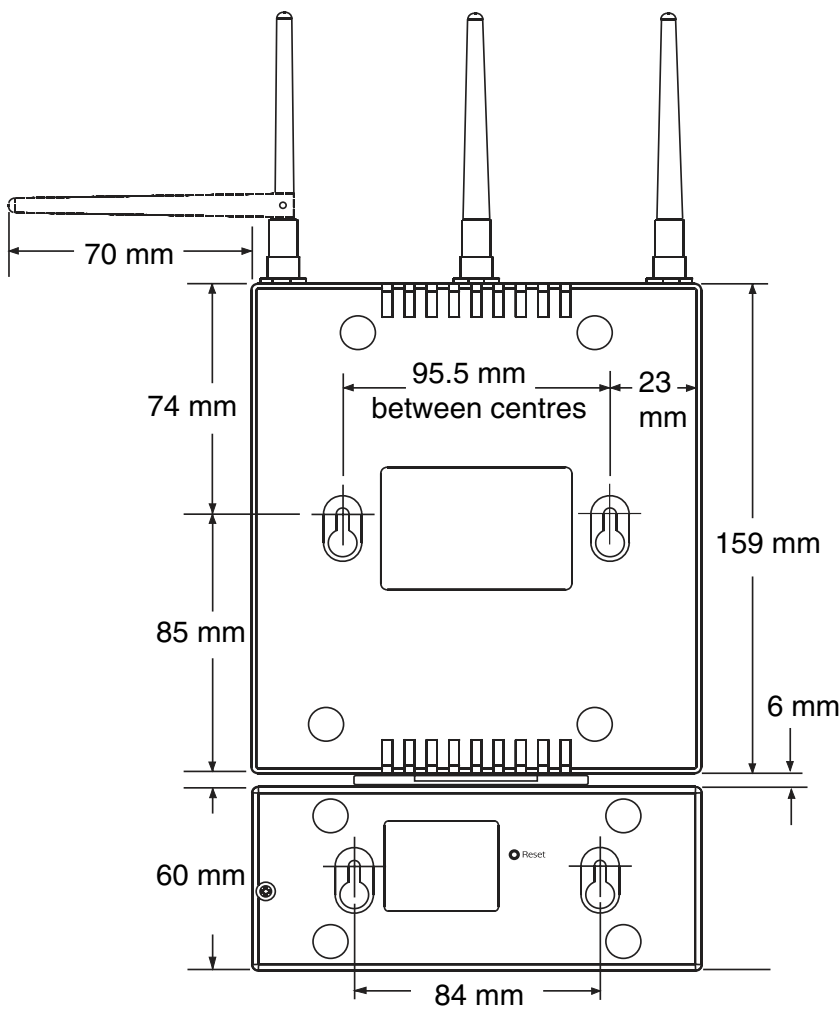

## Clipsal Australia Pty Ltd

A member of Schneider Electric

### Head Office

33-37 Port Wakefield Road,  
Gepps Cross, South Australia 5094

### CIS Technical Support Hotline:

<b>Australia</b>	<b>1300 722 247</b>
<b>New Zealand</b>	<b>0800 888 219</b>
<b>Northern Asia</b>	<b>+852 2484 4157 (Hong Kong)</b>
<b>South Africa</b>	<b>011 314 5200</b>
<b>Southern Asia</b>	<b>+603 7665 3555 x236 or 242</b>
<b>United Kingdom</b>	<b>+44 870 608 8 608</b>
<b>Technical Support Email</b>	<b>cis_support@clipsal.com.au</b>

### National Customer Care Enquiries:

**1300 2025 25**

### National Customer Care Facsimile:

**1300 2025 56**

<b>New Zealand</b> Schneider Electric (NZ) Ltd	Tel +64 9 576 3403
<b>Malaysia</b> Clipsal Integrated Systems (M) Sdn Bhd	Tel +60 3 7665 3555
<b>Singapore</b> Clipsal Integrated Systems Pte Ltd	Tel +65 6415 3232/3233
<b>China</b> Clipsal China Limited	Tel +86 755 8237 5959
<b>Greece</b> Schneider Electric AE	Tel +30 69 4646 3200
<b>Hong Kong</b> Clipsal Integrated Systems (HK) Limited	Tel +852 2487 0261
<b>India</b> Schneider Electric India Pvt Ltd	Tel +91 11 5159 0000
<b>Indonesia</b> PT Clipsal Graha Nusa	Tel +62 21 630 6430

### Korea

Clipsal Korea Co. Ltd

Tel +82 549 5550

### Pakistan

Clipsal Pakistan (Pvt) Ltd

Tel +92 21 506 7278

### Philippines

Clipsal Philippines Inc.

Tel +632 683 0275-78

### South Africa

Clipsal South Africa (Pty) Ltd

Tel +27 11 314 5200

### Taiwan

Clipsal (Taiwan) Co Ltd

Tel +886 2 2558 3456

### Thailand

Clipsal Thailand Ltd

Tel +66 2 952 5338-42

### United Arab Emirates

Clipsal Middle East

Tel +971 6 5570 777

### United Kingdom

Clipsal Integrated Systems  
c/o Schneider Electric

Tel +44 870 608 8 608

### Vietnam

Clipsal - VTEC

Tel +848 856 3002

You can find this datasheet and many others online in PDF format at: [clipsal.com](http://clipsal.com)

[clipsal.com/cis](http://clipsal.com/cis)

Clipsal Australia Pty Ltd reserves the right to change specifications, modify designs and discontinue items without incurring obligation and whilst every effort is made to ensure that descriptions, specifications and other information in this catalogue are correct, no warranty is given in respect thereof and the company shall not be liable for any error therein.

© Clipsal Australia Pty Ltd

This material is copyright under Australian and international laws. Except as permitted under the relevant law, no part of this work may be reproduced by any process without prior written permission of and acknowledgement to Clipsal Australia Pty Ltd. The identified trademarks and copyrights are the property of Clipsal Australia Pty Ltd unless otherwise noted.



CLIPCOM19457 June 2009

O/N19457

CIS1-0010