



Clipsal Digilant® Security Camera

5480DCSD

The Clipsal Digilant 5480DCSD is a state of the art digital security camera that captures high-resolution colour images when motion is detected within its field of view. The images are stored on a removable memory card for easy viewing on a computer or PDA. The camera can also be externally triggered from a window, door opening, and cash register or alternatively can be configured to capture images on a time-lapse basis. The camera can be configured by the software to capture images upon arming and disarming. Depending on the selected resolution and memory card size, the camera can store up to 65,000 images.

The Digilant Security Camera is a low cost alternative to CCTV systems and is ideal for detecting intruders in the home, office or retail shop, by simply connecting it to existing alarm systems.

To complement the Digilant Security Camera in alarm systems, the

5480DPIR Clipsal Digilant motion detector can also be used. Its appearance is identical to the range of Clipsal Digilant Security Cameras. Therefore it can be used as a drop-in replacement for existing PIR motion detectors to ensure visual continuity where cameras are not required in all monitored areas. The combination of identical looking cameras and PIR detectors on a security system can deceive intruders and prevent the cameras being vandalised during a break-in.

To guarantee a fast and easy setup, the Digilant Security Camera comes pre-configured with all the settings required for alarm system operation and only requires that the time and date be set. This is done by simply inserting the memory card into the USB Memory Card Reader then into a computer or PDA that has the Digilant software installed.

Features & Characteristics

- Direct replacement for existing alarm system motion detectors
- Can be installed together with identical looking Digilant motion detectors
- Auto-arm function for easy setup
- Customised image-capture sequence
- Pre-Trigger image capture
- Image encryption
- Time and date stamped images with programmable text overlay
- External trigger input
- Arm/disarm image capture
- Flexible scheduler for independent arming and disarming of camera
- Time and date stamped event log
- High speed image viewer included with setup software
- Digital signature including camera ID within each image for integrity verification.

Technical Specifications

Camera and Accessories

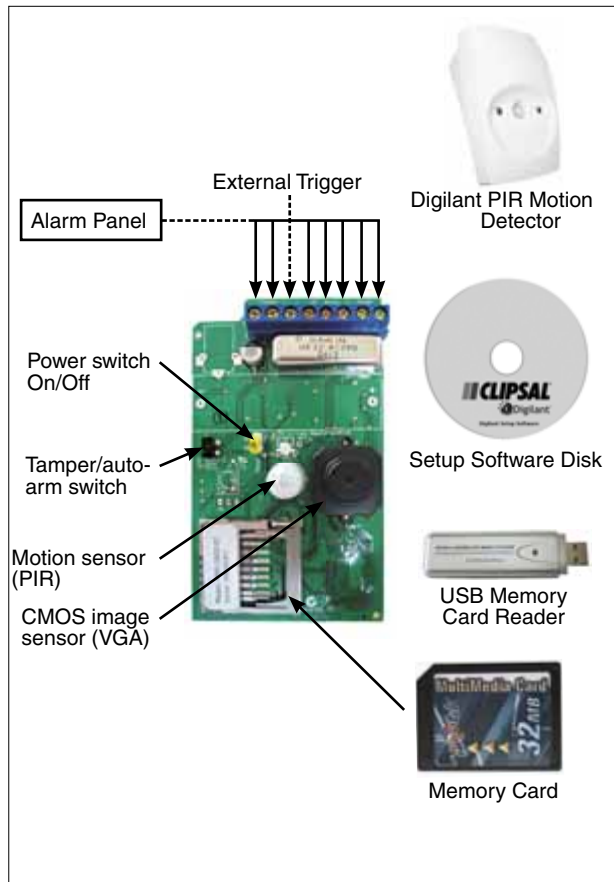

Accessories

| CATALOGUE NO. | Description |
|---------------|-------------------------------|
| 5480DMMC64 | Digilant 64MB MMC Memory Card |
| 5480DMMC1G | Digilant 1GB MMC Memory Card |
| 5480DMCR | Digilant USB MMC Reader |
| 5480DSS | Digilant Setup Software |
| 5480DPS | Digilant Pocket PC Software |
| 5480DPIR | Digilant PIR Detector |

| | | |
|----------------------------|---|--|
| Image Type | 24 bit Colour, JPEG compressed VGA (640 x 480 pixels), QVGA (320 x 240 pixels) | |
| Camera Angle | 70 degrees horizontal, 53 degrees vertical | |
| Image Sensor Sensitivity | 1.0V/Lux-sec | |
| Motion Sensor | Type: PIR Range: 0-5 m (minimum), 0-12 m (typical) Field of View: 100° horizontal, 82° vertical | |
| Memory Card | MultiMediaCard™ (MMC), FAT16 file format | |
| Approximate Image Capacity | 32MB MMC VGA: 800 images QVGA: 2200 images | 1GB MMC VGA: 22,000 images QVGA: 65,000 images |
| External Power Supply | 9V d.c. to 13.8V d.c. 200 mA | |
| Relay Specifications | 200V d.c. 1 A | |
| Power Consumption | Standby: 3 mA Running: 95 mA Charging: 200 mA | |
| Case Dimensions | 116 x 67 x 55 mm | |
| Weight | 102g, 140g (Including packaging) | |
| Operating Temperature | 0° C to 50° C | |

Typical Alarm Installation

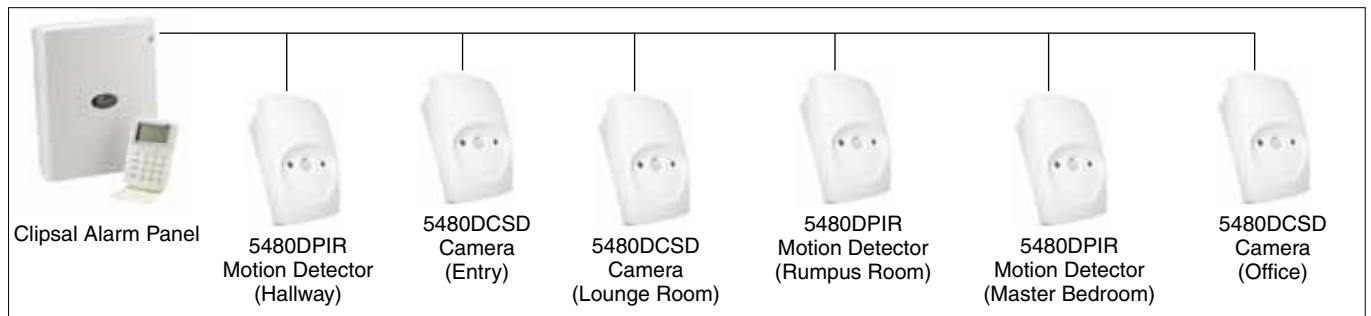

Product of
Clipsal Integrated Systems
 A division of Clipsal Australia Pty Ltd
 ABN 27 007 873 529

Head Office
 12 Park Terrace, Bowden
 South Australia 5007
 PO Box 103 Hindmarsh,
 South Australia 5007

Telephone (08) 8345 9500
 International +61 8 8345 9500
 Facsimile (08) 8346 0845
 International +61 8 8346 0845
 Internet www.clipsal.com/cis
 E-Mail cis@clipsal.com.au

CIS Technical Support Hotline:
 1300 722 247 (Australia only)

Customer Service Enquiries:
1300 2025 25

National Customer Service Facsimile:
1300 2025 56

International Enquiries

International Sales and Marketing
 Telephone +61 8 8269 0587
 Facsimile +61 8 8340 7350
 E-Mail export@clipsal.com.au

New Zealand
 Clipsal Industries (NZ) Ltd
 Telephone +64 9 576 3403

Disclaimer Clipsal Integrated Systems reserves the right to change specifications or designs described in this data sheet without notice and without obligation.



© Clipsal Australia Pty Ltd 2007.
 Created in Australia 2007. All rights reserved.
 HomeSafe™ is a trademark of
 Clipsal Australia Pty Ltd