

CLIPSAL



C-Bus

Control and Management System

C-Bus Telephone Interface

Installation Instructions

5100T Series

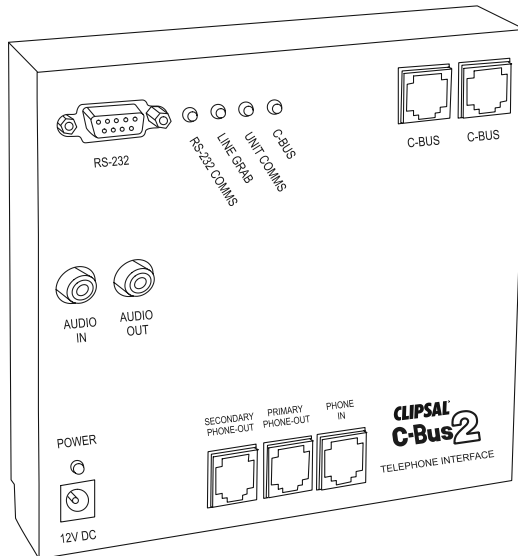

© Copyright Clipsal Integrated Systems Pty Ltd 2004. All rights reserved. This material is copyright under Australian and international laws. Except as permitted under the relevant law, no part of this work may be reproduced by any process without prior written permission of and acknowledgement to Clipsal Integrated Systems Pty Ltd.

Clipsal, C-Bus and StarServe are registered trademarks of Clipsal Australia Pty Ltd.

The information in this manual is provided in good faith. Whilst Clipsal Integrated Systems (CIS) has endeavoured to ensure the relevance and accuracy of the information, it assumes no responsibility for any loss incurred as a result of its use. CIS does not warrant that the information is fit for any particular purpose, nor does it endorse its use in applications which are critical to the health or life of any human being. CIS reserves the right to update the information at any time without notice.

V2.0 Nov 2004

Contents

1.0	Product Range	5
2.0	Important Notes	5
3.0	Abbreviations	5
4.0	Description	5
5.0	Electrical Wiring	6
6.0	Status Indicators	7
	6.1 Power Indicator	7
	6.2 C-Bus Indicator	7
	6.3 Unit Comms Indicator	8
	6.4 Line Grab Indicator	8
	6.5 RS-232 Comms Indicator	9
7.0	Connection to the Telephone System	9
	7.1 Parallel	10
	7.2 Mode 3	10
	7.3 Insertion into Local Circuit	11
	7.4 Security System Considerations	12
	7.5 RJ12 Telephone Connector Wiring	13
8.0	Installation Procedure	14
9.0	C-Bus Network Connection	15
10.0	Connection to a Personal Computer	16
11.0	Communications Protocol	18
12.0	Power Requirements	18
	12.1 C-Bus Power	18
	12.2 Plug Pack Power	18
13.0	C-Bus System Clock	18
14.0	Built-in PCI	19
15.0	Programming and Commissioning	19
16.0	Accessories	19
17.0	Electrical Specifications	20
18.0	Mechanical Specifications	21
19.0	Standards Complied	22
20.0	Limited Warranty	22
21.0	Special Conditions for New Zealand	22

1.0 Product Range

5100T Series C-Bus Telephone Interface

This product is packaged for a number of different countries, each with its own specific requirements. Refer to the product catalogue number to determine suitability.

2.0 Important Notes

Answering machine products that hang up an answered call when a local handset pickup is detected may not work satisfactorily with the C-Bus Telephone Interface. Any answering machine product used on the same line as the Telephone Interface should not be of this type.

The use of any software not provided by Clipsal Integrated Systems (CIS) in conjunction with the installation of this product may void any warranties applicable to the hardware.

3.0 Abbreviations

CBTI	C-Bus Telephone Interface
DTMF	Dual Tone Multiple Frequency
PABX	Private Automatic Branch Exchange
PSTN	Public Switched Telephone Network

4.0 Description

The C-Bus Telephone Interface offers a dial-in and dial-out facility, permitting control and status monitoring for a C-Bus system. It also includes an audio output, so that C-Bus events can be audibly announced.

The Telephone Interface is programmed using a connection to a PC running special configuration software. The interface can also act as a 5500PC C-Bus PC Interface. In this way C-Bus can be programmed and configured either locally or from a remote site using a data modem.

The Telephone Interface is suitable for connection to the telephone network using a Mode 3 connection, in parallel, or by insertion into a local circuit. It can be installed as a stand-alone item with connection to C-Bus, or into a Clipsal StarServe cabinet.

The Telephone Interface unit is packed* with the following:

- 1 × 12 V DC plug pack
- 1 × RS-232 cable (DB9F to DB9M), 2 metres
- 1 × RJ45 patch lead, 300 mm
- 2 × RJ12 patch leads, 1 metre
- Installation Instructions (this booklet)
- CD-ROM containing the Telephone Interface Configuration software and installation Instructions in PDF format
- Software licence agreement
- Warranty and registration card

* May vary for different countries. Subject to change without notice.

5.0 Electrical Wiring

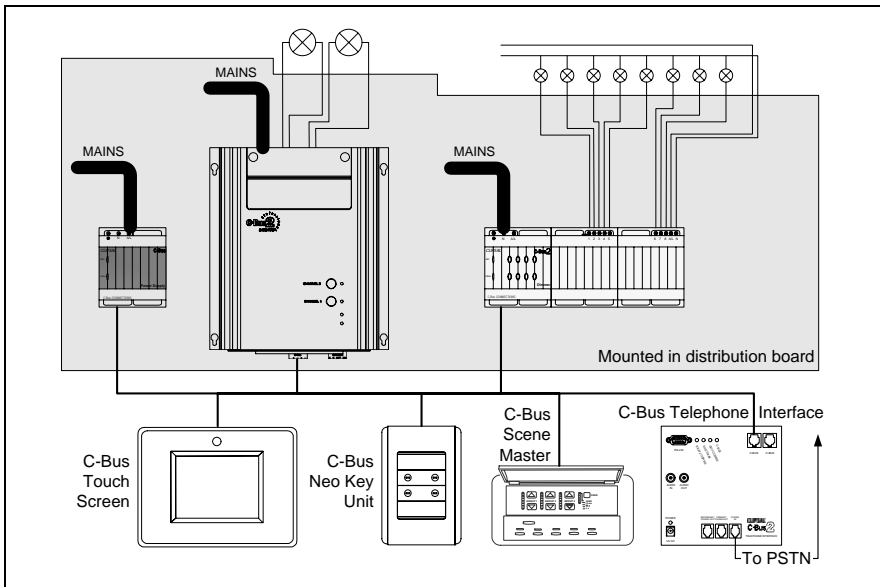

Figure 1 – The 5100T is mounted separately to the distribution board

All modules of the C-Bus 2 system must be wired together using high voltage rated cable. Clipsal recommends the use of cable with a breakdown voltage rated higher than 3750 volts. Failure to do so negates the Australian and New Zealand Electrical Wiring regulations. A suitable cable is Clipsal catalogue number 5005C305B.

The C-Bus Telephone Interface must not be placed within a mains distribution board. It is connected to the C-Bus and Telco networks, as shown in Figure 1.

The 5005C305B C-Bus system cable is isolated from the mains at 3750 V AC for 1 minute, in accordance to UL Standards. It is tested and complies with the appropriate AS/NZ Standards to co-exist within the distribution board as building cable.

6.0 Status Indicators

6.1 Power Indicator

This indicates that the power pack is connected to the unit.

Indicator Status	Meaning
On	Power pack connected and switched on
Off	Power pack not connected or switched off.

Table 1 – Power indicator status

6.2 C-Bus Indicator

This indicator shows the status of the C-Bus network at this unit. If sufficient network voltage and a valid C-Bus clock signal are present, the indicator will be illuminated. If a network is connected which has more current load than the power supplies can support, the indicator will flash to show a marginal network voltage. If there is no C-Bus power present, the indicator will not light.

Indicator Status	Meaning
On	C-Bus power on and functional
Flashing	Insufficient C-Bus power to support network
Off	No C-Bus clock present, insufficient power to support network or C-Bus not connected

Table 2 – C-Bus Indicator status

Debugging of possible network problems can be achieved with the Clipsal C-Bus Network Analyser tool (5100NA).

6.3 Unit Comms Indicator

If the unit is powered and connected to C-Bus, this indicator will be illuminated and steady. During internal communication between the Telephone Interface and C-Bus, the indicator will flash.

Indicator Status	Meaning
On	C-Bus power on and functional
Flashing	Data exchange in progress
Off	C-Bus not connected

Table 3 – Unit Comms indicator status

6.4 Line Grab Indicator

The Line Grab indicator illuminates when the Telephone Interface has an active connection to the telephone line.

Indicator Status	Meaning
On	Phone line in use
Off	Phone line not in use

Table 4 – Line Grab indicator status

6.5 RS-232 Comms Indicator

This indicator flashes when data is transferred through the RS-232 port.

Indicator Status	Meaning
Flashing	Data transmission in progress
Off	No data transmission

Table 5 – RS-232 Comms indicator status

7.0 Connection to the Telephone System

The C-Bus Telephone Interface has three telephone connectors, providing flexible connection to the telephone network and equipment. These are shown in Table 6.

Connection	Description
Phone In	Used for the connection to the telephone network. This connector is also wired so that the Primary Phone Out signals are available, permitting a simple Mode 3 connection.
Primary Phone Out	Used for connection to local telephone devices, for example handsets. These local devices can be used for control of the C-Bus Telephone Interface.
Secondary Phone Out	Used for connection to local telephone devices, for example fax and answering machines. These devices cannot be used for control of the C-Bus Telephone Interface. Additionally, these devices are switched off when the C-Bus Telephone Interface is being controlled by a device attached to the Primary Phone Out.

Table 6 – The 5100T telephone connectors

The most common connection methods are described in the following sections.

7.1 Parallel

A parallel connection is the simplest. Using this connection, the Telephone Interface cannot take over the line for dialling out. While use of a local telephone for programming may be possible, it is not recommended because of the telephone line dial tones. There may also be interference when DTMF tones (or decadic dialling pulses) are forwarded onto the telephone network. This type of connection is shown in Figure 2.

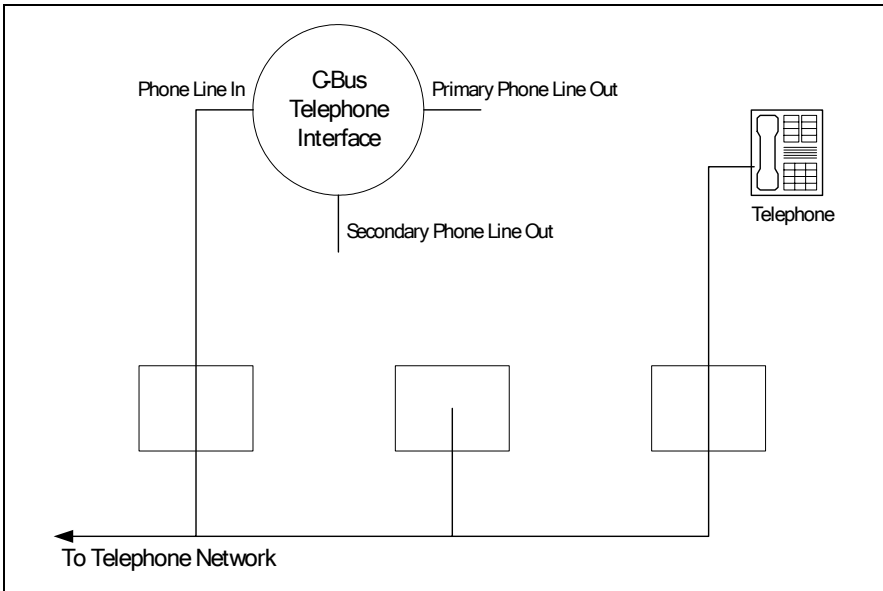

Figure 2 – A parallel connection

7.2 Mode 3

A mode 3 connection requires a special mode 3 socket, installed by the telephone company.

Such a connection loops the telephone line through the Telephone Interface, which can take over the line. All other telephones are downstream of the mode 3 connection point. This type of connection is shown in Figure 3. The Telephone Interface “Phone In” connector takes the incoming telephone line, and returns the mode 3 switched signals. These are the same as the Primary Phone Out signals.

A mode 3 connection allows control of the C-Bus Telephone Interface using a local telephone handset. A fax and answering machine can be connected directly to the Secondary Phone Out connector (ensure they are isolated if a local handset is used to control the C-Bus Telephone Interface).

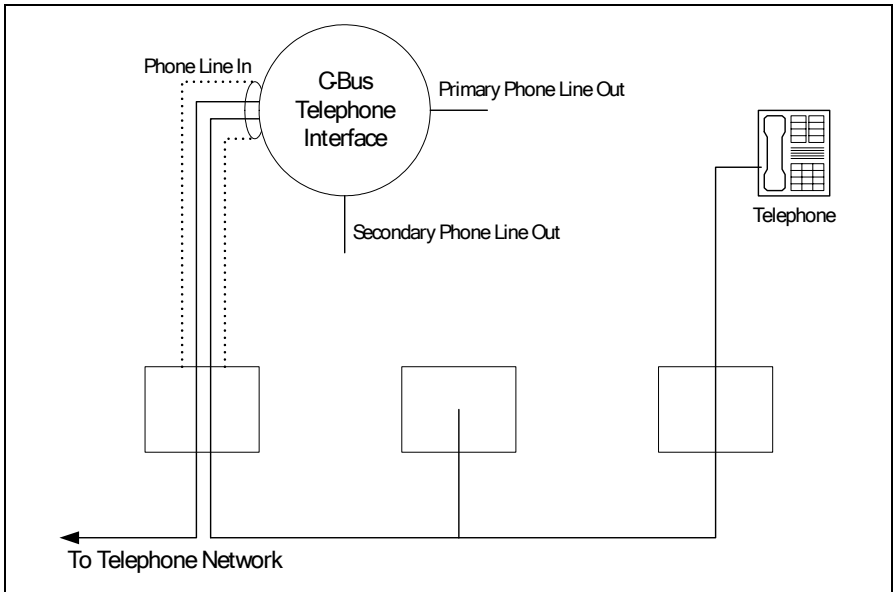

Figure 3 – A mode 3 connection

7.3 Insertion into Local Circuit

The C-Bus Telephone Interface can be inserted into a local telephone distribution circuit. In this case, it would be installed in a telephone distribution cabinet (such as Clipsal StarServe). It would be the primary point at which the external telephone network is terminated.

The behaviour is the same as mode 3, but the connection is slightly different (refer to Figure 4). The Phone In connector takes the incoming telephone line. Primary Phone Out and Secondary Phone Out are connected to the local telephone distribution system.

This approach is functionally the same as the mode 3 connection, but with simple wiring using patch leads.

As before, the Secondary Phone Line Out connection should be used for fax and answering machines, which could otherwise be interfered with when a handset is used for local control of the C-Bus Telephone Interface.

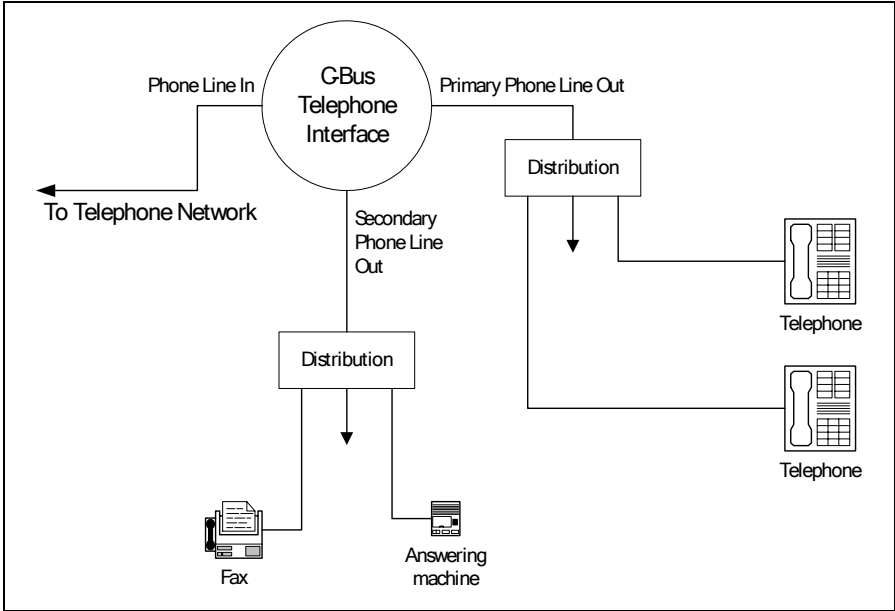

Figure 4 – Insertion into a local telephone distribution circuit

7.4 Security System Considerations

When using a security system with the C-Bus Telephone Interface, it is important that the correct connection is made to the telephone system.

A security system should always be connected using mode 3, and be the first device in line from the telephone network. This makes the security system the master device, and allows it to take control of the telephone line at any time.

7.5 RJ12 Telephone Connector Wiring

There are two valid methods of telephone connector wiring. These are illustrated in Figures 5 and 6.

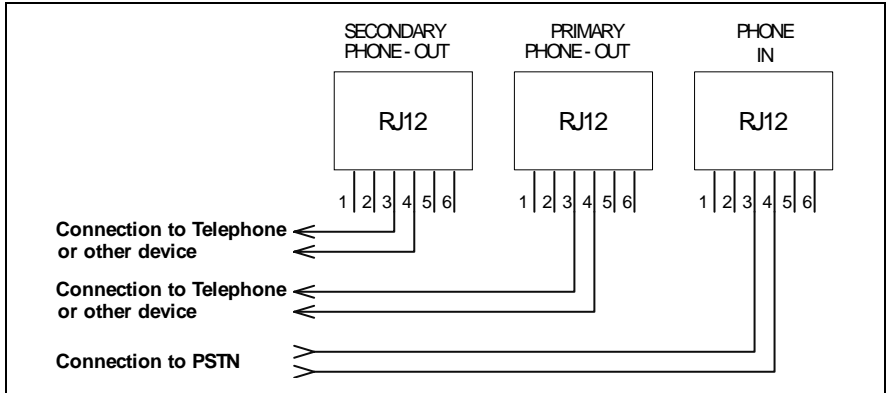

Figure 5 – Telephone connector wiring

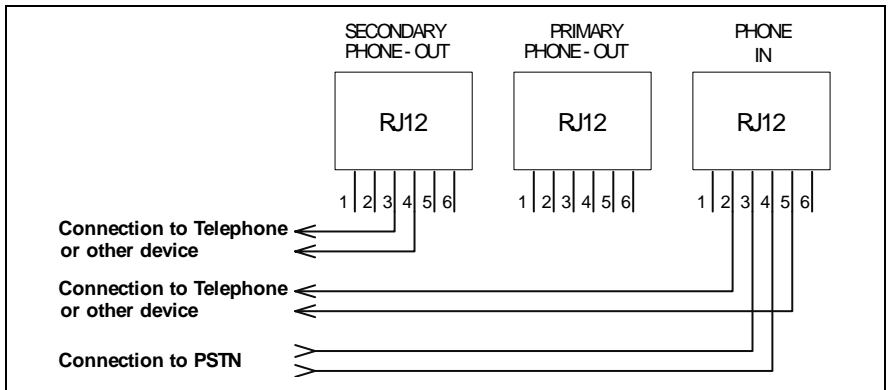

Figure 6 – Alternative telephone connector wiring

8.0 Installation Procedure

There are two options for mounting the C-Bus Telephone Interface:

- direct screw attachment via keyhole opening at the back of the unit (80 mm mounting centres)
- clipping into a Clipsal StarServe cabinet using an optional 5100TMB mounting bracket (shown in Figure 7).

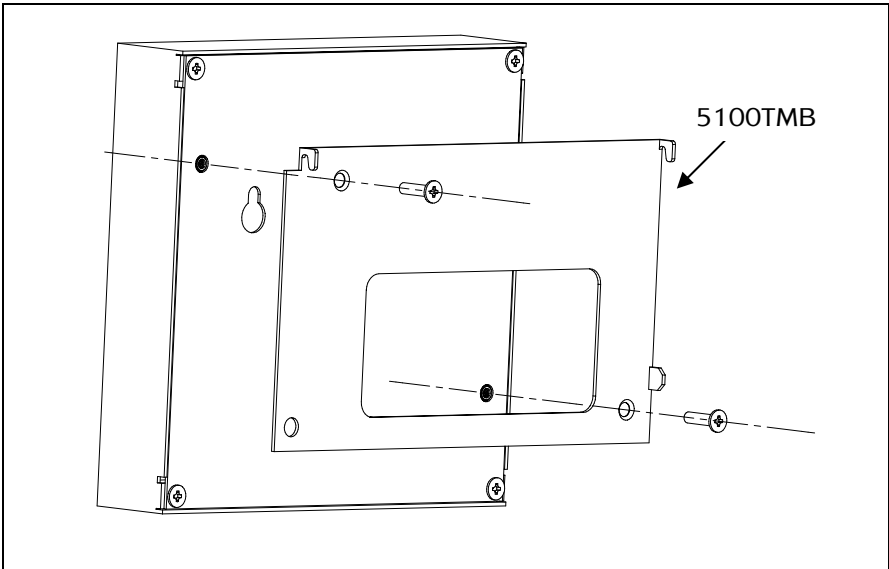

Figure 7 – Using a 5100TMB mounting bracket

9.0 C-Bus Network Connection

Installation of the Telephone Interface on the C-Bus network requires connection to the unshielded twisted pair C-Bus cable. Connection should be made using Category 5 (Cat-5) data cable, Clipsal catalogue number 5005C305B.

Figure 8 and Table 7 identify the connections required from the Telephone Interface to the C-Bus network using Cat-5 cable.

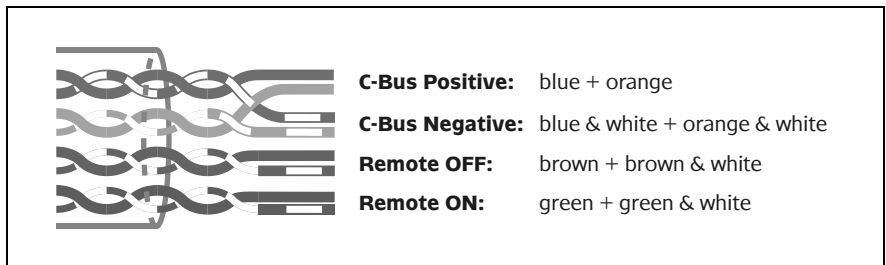

Figure 8 – C-Bus cable conductor assignments

Pin	C-Bus Connection	Colour
1	Remote ON	green & white
2	Remote ON	green
3	C-Bus Negative (-)	orange & white
4	C-Bus Positive (+)	blue
5	C-Bus Negative (-)	blue & white
6	C-Bus Positive (+)	orange
7	Remote OFF	brown & white
8	Remote OFF	brown

Table 7 – RJ45 socket C-Bus pinouts



The Telephone Interface does not have Remote Override functions (Remote ON/Remote OFF). However, these connections must be maintained for correct operation of these services across the C-Bus network.

10.0 Connection to a Personal Computer

The connection to a personal computer (PC) is via a 9 pin D type serial connector. This connection needs to be made to the 9 pin serial port of the PC. If the PC only has a 25 pin serial socket available, an adaptor will be required (25 to 9 pin adaptors are readily available from most computer stores).

A data cable with a DB9 socket at one end and a DB9 plug at the other is supplied with the Telephone Interface.

Table 8 identifies the connections used by the Telephone Interface RS-232 connector.

C-Bus Telephone Interface		Personal Computer	
Pin	Signal	Pin	Signal
1	Data Carrier Detect (DCD)*	1	Data Carrier Detect
2	Transmit Data (TX)	2	Receive Data
3	Receive Data (RX)	3	Transmit Data
4	Data Set Ready (DSR)*	4	Data Terminal Ready
5	Common (COM)	5	Common
6	Data Terminal Ready (DTR)*	6	Data Set Ready
7	Clear to Send (CTS)*	7	Request to Send
8	Request to Send (RTS)*	8	Clear to Send
9	Ring Indicator (RI)*	9	Ring Indicator

Table 8 – RS-232 connections

*Not required

The 5100T unit's RS-232 serial port is internally wired as a null modem terminal device, as shown in Figure 9.

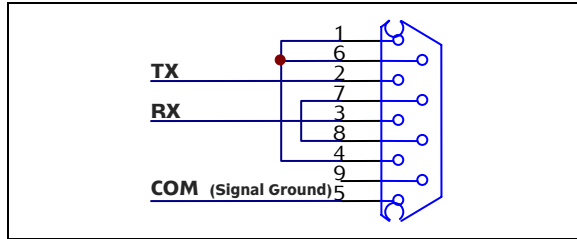

Figure 9 – Internal wiring of the RS-232 serial port

In very rare cases this type of connection can cause a software driver failure of certain third party PC serial port extenders (external serial port boxes).

In such cases the complete operating system boot process may fail when the 5100T Series unit is connected. If this problem occurs, one of the following tasks is recommended:

- Disconnect the 5100T Series unit during the boot process.
- Modify the RS-232 serial communication cable so that only three wires connect between the C-Bus 5100T Series unit and the computer; the Transmit (TXD), Receive (RXD) and Signal Ground (COM) wires. Refer to Figure 10.

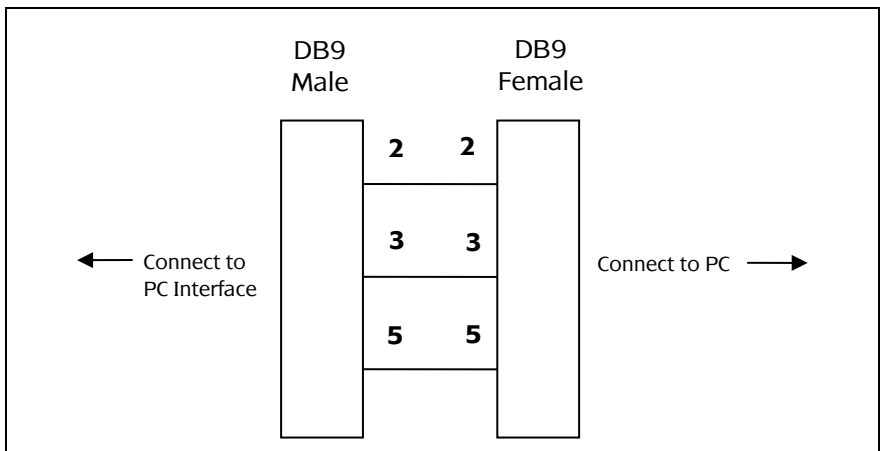

Figure 10 – RS-232 serial cable modification

11.0 Communications Protocol

A C-Bus network is connected to a PC for system configuration and programming, (refer to Programming and Commissioning on page 19). The Telephone Interface uses a proprietary protocol, based on RS-232 serial communications. Clipsal offers a PCI Development Kit (5000DK) which enables third party developers to integrate their systems with C-Bus. Contact your nearest Clipsal Integrated Systems sales office for further details.

12.0 Power Requirements

The Telephone Interface requires connection to the C-Bus network and a 12 V DC plug pack for operation.

12.1 C-Bus Power

The C-Bus Telephone Interface draws 18 mA from the C-Bus network. Adequate C-Bus Power Supply Units must be installed to support the connected devices. If in doubt, use the C-Bus Calculator software.

12.2 Plug Pack Power

The unit also requires the connection of a 12 V DC plug pack, from which it draws between 300 and 500 mA. The plug pack has a 2.1 mm plug with centre pin positive.

13.0 C-Bus System Clock

The Telephone Interface incorporates a software selectable C-Bus System Clock. This is used for synchronising data communication waveforms on the C-Bus network. No more than three units on any C-Bus network should have active Clock circuitry. This option is normally disabled using the C-Bus Toolkit software.

14.0 Built-in PCI

This product includes a C-Bus PC Interface (PCI), accessible through the front panel D type RS-232 connector. The following special points apply:

- When the 5100T is used as a PC Interface, the normal telephone answer and dial operations are suspended.
- This interface is designed for aiding C-Bus network commissioning. It should not be used for permanent connection of devices to a C-Bus interface (e.g. some alarm systems or automation controllers). These devices should use a separate dedicated PCI.
- Reprogramming the internal PCI can render the 5100T inoperative.

15.0 Programming and Commissioning

The Telephone Interface must be programmed with a unique identification (Unit Address) and mode of operation on the C-Bus network. This is achieved using the C-Bus Toolkit software.

16.0 Accessories

5100TMB Mounting bracket to suit Clipsal StarServe enclosure

17.0 Electrical Specifications

Parameter	Description
C-Bus supply voltage	15 to 36 V DC @ 18 mA nominal
DC plug pack	12 V DC @ 300 to 500 mA, 2.1mm plug with centre pin positive
Ringer Equivalence Number	1
Audio output	Line output, 1 V p-p (nominal) into 10 kΩ
C-Bus unit type	PC_CBTI
Control functions	Dial-in and dial-out facility, control and status monitoring for a C-Bus system. Audio output. Standard C-Bus PCI allowing remote Dial In and operation as a PCI with modem connection for remote operation of installation software.
Status indicators	Green LED: Power. Orange LED: RS232 Comms, Line Grab, Unit Comms and C-Bus.
Start up time	10 seconds nominal after power-up.
Storage temperature	0 to 60 °C
Operating temperature range	0 to 45 °C
Operating humidity range	0 to 95% RH (non-condensing)
C-Bus input terminals	RJ45 sockets

18.0 Mechanical Specifications

Parameter	Description
Colour	White with black lettering and markings
Dimensions (W×H×D)	146.5 × 145 × 30 mm
Weight	580 g
Mounting centres	80 mm

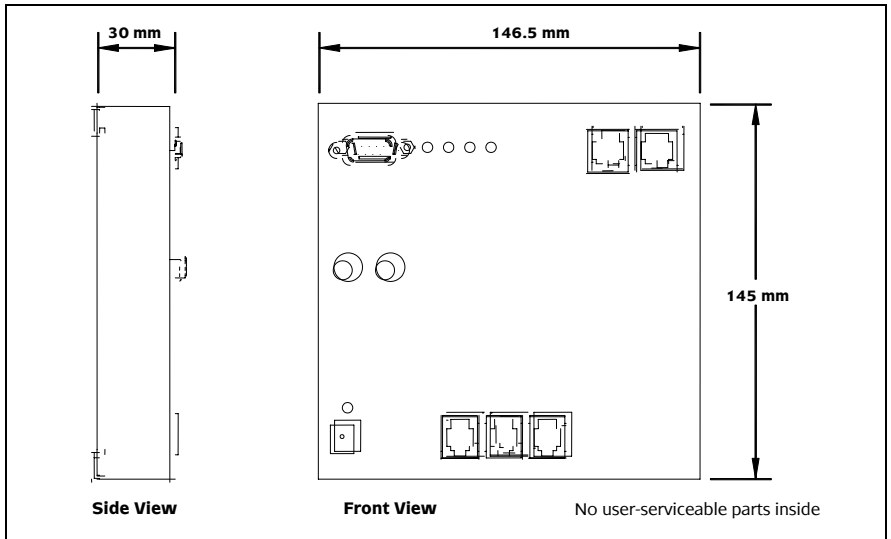

19.0 Standards Complied

Standard/Directive	Title
AS/NZS3548; IEC CISPR22; EN55022	IT Equipment - RFI Emissions Standard
AS/NZS3260	IT Equipment – Safety Standard
EN60950	IT Equipment – Safety Standard
ACA TS 001	Safety Requirements for Customer Equipment
AS/ACIF S002	Analogue interworking and non-interference requirements for Customer Equipment for connection to the PSTN
AS/ACIF S004	Voice frequency performance requirements for Customer Equipment
A-Tick	Meets safety and technical standards for Australian connection to the PSTN.
89/336/EEC	CE EMC Directive
IDA TS PSTN1	Type Approval Specification for Terminal Equipment connection to Public Switched Telephone Network
IDA TS EMC	EMC Requirements for Telecommunication Equipment
PTC 200	Requirements for Analogue Telecommunications Equipment
HKTA 2011	Network connection specification for connection of customer premises equipment (CPE) to direct exchange lines (DEL) of the Public Switched Telephone Network (PSTN) in Hong Kong.

20.0 Limited Warranty

The Clipsal 5100T Series unit carries a two year warranty against manufacturing defects (refer to the supplied Warranty Statement).

21.0 Special Conditions for New Zealand

PTC200 General Warning

The grant of a Telepermit for any item of terminal equipment indicates only that Telecom has accepted that the item complies with minimum conditions for connection to its network. It indicates no endorsement of the product by Telecom, nor does it provide any sort of warranty. Above all, it provides no assurance that any item will work correctly in all respects with another item of Telepermitted equipment of a different make or model, nor does it imply that any product is compatible with all of Telecom's network services.

PTC200 5.4.1 (2) General (decadic signalling)

This equipment must not be programmed for decadic (pulse) dialling because its characteristics are incompatible with the telephone exchanges in New Zealand. DTMF (tone) dialling is considerably faster and is fully compatible.

PTC200 8.1.7 (a) User Instructions (automatic call set-up)

This equipment should not be used under any circumstances that may constitute a nuisance to other Telecom customers.

PTC200 8.1.7 (b) User Instructions (automatic call set-up))

This equipment shall not be set up to make automatic calls to Telecom's 111 Emergency Service.

PTC 200 8.1.8 (b) Call Logging

The call log incorporated in this equipment does not record all answered calls. The call log, therefore, may not agree with the Telecom monthly account that may include calls not shown on the log.

Clipsal C-Bus 2 System Cabling

All modules of the C-Bus 2 System must be wired together using high voltage rated cable. Clipsal Industries (NZ) Limited recommends the use of power cable with a breakdown voltage rated higher than 3750 volts. Failure to do so negates the New Zealand Electrical Wiring Regulations.

Repair Responsibilities of Telecom and Clipsal Industries

Wiring, operation and repair of this Clipsal C-Bus 2 Power Appliance Control System via a Telephone Interface is primarily the responsibility of Clipsal Industries (NZ) limited. If the system is faulty and the customer wants to establish whose responsibility it is to fix the problem, disconnect a patch cord from the C-Bus 2 Telephone Interface. If an ordinary telephone also attached to the line now operates normally do not contact the Telecom Fault Service.

Use with the Telecom Message Manager

This Clipsal C-Bus 2 Remote Controller of Power Appliances will not work with the Telecom Message Manager on the same line. This is because both devices require answering the call after a preset number of rings of the telephone. Consequently one or other of the management systems will never answer a call.

Local Call Charges

If a charge for local calls is unacceptable, the "Dial" button should NOT be used for local calls. Only the 7 digits of the local number should be dialled from your telephone. DO NOT dial the area code digit or the "0" prefix.

Automatic Dial-out Notifications

This equipment can automatically dial numbers to provide notification of C-Bus events. It is the responsibility of the user to set the message played on dial-out to clearly identify the caller, and to ensure this message is repeated at least once.



Technical Support and Troubleshooting

For further assistance in using this product, consult your nearest Clipsal Integrated Systems Sales Representative or Technical Support Officer.

Technical Support Hotline: 1300 722 247 (Australia)
0800 888 219 (New Zealand)

Technical Support Email: techsupport.cis@clipsal.com.au

Sales Support Email: sales.cis@clipsal.com.au

A list of worldwide contacts, additional product information and technical resources is provided at <http://www.clipsal.com/cis/>

Product of Clipsal Integrated Systems Pty Ltd

ABN 15 089 444 931

Head Office

12 Park Terrace, Bowden, SA 5007, Australia

Telephone: (+61) 8 8440 0500

Facsimile: (+61) 8 8346 0845

Email: cis@clipsal.com.au

Web: <http://www.clipsal.com/cis/>

10364281