



## C-Bus DIN Rail Universal Dimmer

### Installation Instructions

L5504D2U

L5504D2UP

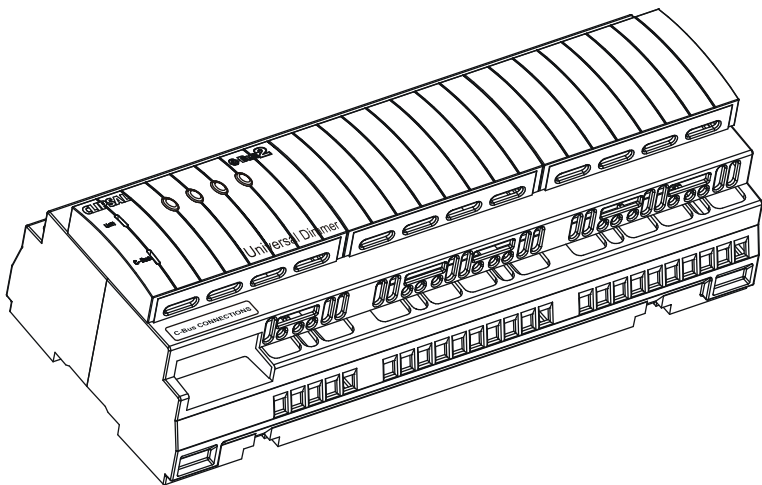

© Copyright Clipsal Australia Pty Ltd 2006. All rights reserved. This material is copyright under Australian and international laws. Except as permitted under the relevant law, no part of this work may be reproduced by any process without prior written permission of and acknowledgement to Clipsal Australia Pty Ltd.

Clipsal and C-Bus are registered trademarks of Clipsal Australia Pty Ltd.

The information in this manual is provided in good faith. Whilst Clipsal Australia Pty Ltd (CAPL) has endeavoured to ensure the relevance and accuracy of the information, it assumes no responsibility for any loss incurred as a result of its use. CAPL does not warrant that the information is fit for any particular purpose, nor does it endorse its use in applications which are critical to the health or life of any human being. CAPL reserves the right to update the information at any time without notice.

V1.0 Mar 2006

# Contents

<b>1.0</b>	<b>Product Range</b>	<b>5</b>
<b>2.0</b>	<b>Important Note</b>	<b>5</b>
<b>3.0</b>	<b>Description</b>	<b>5</b>
<b>4.0</b>	<b>Capabilities</b>	<b>5</b>
<b>5.0</b>	<b>Compatible Loads</b>	<b>6</b>
<b>6.0</b>	<b>Wiring Instructions</b>	<b>7</b>
<b>7.0</b>	<b>C-Bus Network Connection</b>	<b>8</b>
<b>8.0</b>	<b>Features</b>	<b>10</b>
	8.1 Local Override	10
	8.2 Remote Override	10
	8.3 Thermal Monitoring	11
	8.4 Short Circuit Cut-out	11
	8.5 Soft Turn On	12
<b>9.0</b>	<b>Priority of Operating Modes</b>	<b>12</b>
<b>10.0</b>	<b>Status Indicators</b>	<b>13</b>
	10.1 C-Bus Indicator	13
	10.2 Unit Indicator	13
<b>11.0</b>	<b>C-Bus System Clock</b>	<b>14</b>
<b>12.0</b>	<b>C-Bus Network Burden</b>	<b>14</b>
<b>13.0</b>	<b>Power-Up Load Status</b>	<b>15</b>
<b>14.0</b>	<b>C-Bus Power Requirements</b>	<b>15</b>
<b>15.0</b>	<b>Power Surges</b>	<b>16</b>
<b>16.0</b>	<b>Megger Testing</b>	<b>16</b>
<b>17.0</b>	<b>Programming</b>	<b>16</b>
<b>18.0</b>	<b>Electrical Specifications</b>	<b>17</b>
<b>19.0</b>	<b>Mechanical Specifications</b>	<b>18</b>
<b>20.0</b>	<b>Standards Complied</b>	<b>19</b>



## 1.0 Product Range

Catalogue No.	Channels	Supply Voltage (50 Hz)	On-Board Power Supply
L5504D2U	4	220 to 240 V	✓
L5504D2UP	4	220 to 240 V	✗

## 2.0 Important Note

The use of any software not provided by Clipsal Integrated Systems (CIS) in conjunction with the installation of these products may void any warranties applicable to the hardware.

## 3.0 Description

The L5504D2U and L5504D2UP are C-Bus 4 channel universal phase control dimmers which are compatible with a range of load types (see Section 5.0). They are designed to be used in switchboard distribution applications. The units are DIN rail mounted, measuring 12 modules wide (1 module = 17.5 mm). C-Bus connection is achieved through the use of RJ45 connectors, allowing similar units to be quickly looped together.

## 4.0 Capabilities

The L5504D2U and L5504D2UP contain four independently isolated two-wire dimmer channels with an Active and Load terminal. Each channel automatically selects the appropriate phase control operating mode to suit its load:

- trailing edge for incandescent and capacitive input electronic transformer based LV lighting
- leading edge for iron-core transformer based LV or neon lighting and other inductive load types such as fan motors.

Each channel may be wired to any mains voltage phase in multi-phase supply installations.

The C-Bus L5504D2U DIN Rail Universal Dimmer has an internal power supply capable of supporting a number of other C-Bus units (200 mA capacity). The L5504D2UP does not have a C-Bus power supply, but consumes no current from the C-Bus network during normal operation.

These units are capable of generating a C-Bus system clock signal, providing all the support necessary for a simple C-Bus network. Local toggle buttons are provided on each unit to allow individual channels to be switched locally (overriding the current C-Bus state). Remote ON and OFF facilities are available, permitting all channels to be turned on or off without C-Bus network communication. These units isolate mains power from the extra low voltage C-Bus network.

## 5.0 Compatible Loads

Table 1 shows the loads which are compatible with the C-Bus DIN Rail Universal Dimmers. Each channel has a maximum load current rating of 2.5 Amps.





Load Symbol	Compatible Loads	Load Rating per Channel	Lamp Rating*	
			at 220 V AC	at 240 V AC
	Incandescent lighting Halogen 240 V lamps	2.5 A	550 W	600 W
	Low voltage lighting with electronic transformers			
	Low voltage or neon <sup>‡</sup> lighting with iron-core transformers		450 W	500 W
	§Exhaust fans (shaded pole induction motors) §Ceiling fans (permanent-split-capacitor motors)		–	–

Table 1 – Loads compatible with the L5504D2U and L5504D2UP

\* Estimated lamp rating taking into account transformer losses, etc.

‡ Neon lamps must be used in conjunction with a 2 or 4 Amp MCB and a Clipsal 5100NLA Neon Lighting Adaptor.

- § The installer must ensure that an appropriate manually operated mechanical isolating switch and circuit breaker is installed with the motor, in order to comply with local wiring rules applicable to the region.

## 6.0 Wiring Instructions

The L5504D2U and L5504D2UP units are capable of handling up to 10 Amps across four dimmed channels (2.5 Amps per channel). Consider the maximum current draw and the unit's terminal size when selecting cables. The load supply should be protected by a 10 Amp circuit breaker.

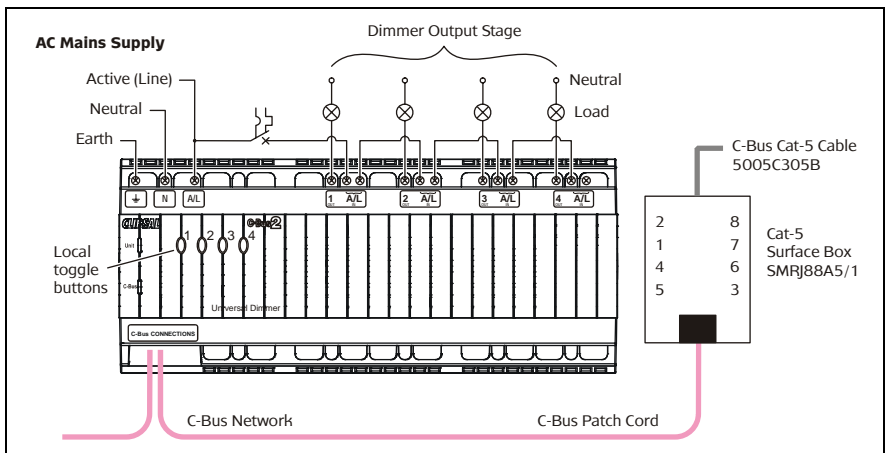

Figure 1 - L5504D2Ux wiring

A wiring diagram for the C-Bus DIN Rail Universal Dimmers is provided in Figure 1. Consider the following points when installing these units:

- A maximum of 10 L5504D2U units (with 200 mA power supply) can be connected to a single C-Bus network. A maximum of 100 L5504D2UP units (with no power supply) may be connected.
- Fix mains cabling in the distribution board using cable ties or trunking as required by local cabling rules. Take care not to allow copper strands to enter the DIN unit's apertures.
- Rubber bungs are supplied for unused RJ45 connectors, to stop foreign bodies from entering the unit. Always install these bungs when the unit is mounted inside a mains rated enclosure.

To meet the safety requirements of IEC60669-2-1 a Miniature Circuit Breaker (MCB) must be installed in each channel as illustrated in Figure 2.

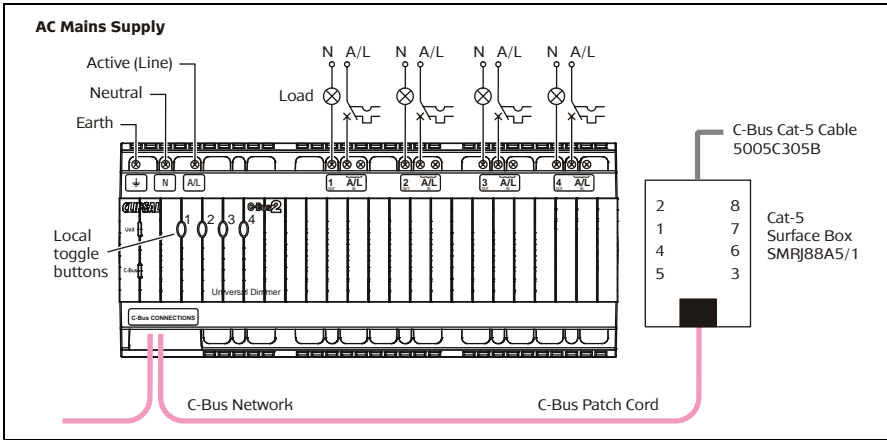

Figure 2 – L5504D2Ux wiring to meet IEC60669-2-1 safety requirements

## 7.0 C-Bus Network Connection

Connection to the C-Bus network is made via one of the RJ45 sockets. Use Cat-5 Unshielded Twisted Pair (UTP) C-Bus cable, and an appropriately wired RJ45 plug. Pinouts and cable conductor assignments are provided in Figure 3 and Table 2. The RJ45 sockets are internally connected. The Clipsal catalogue number for the C-Bus Cat-5 UTP cable is 5005C305B.

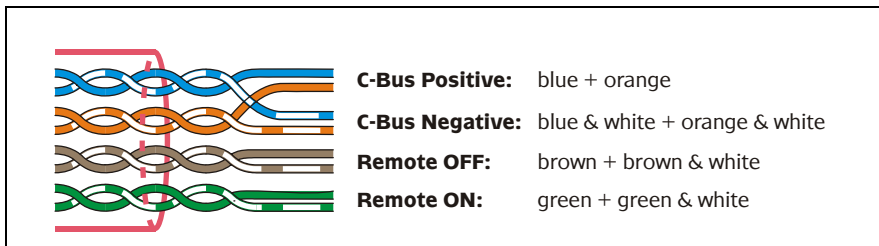

Figure 3 – C-Bus cable conductor assignments

Pin	C-Bus Connection	Colour
1	Remote ON	green & white
2	Remote ON	green
3	C-Bus Negative (-)	orange & white
4	C-Bus Positive (+)	blue
5	C-Bus Negative (-)	blue & white
6	C-Bus Positive (+)	orange
7	Remote OFF	brown & white
8	Remote OFF	brown

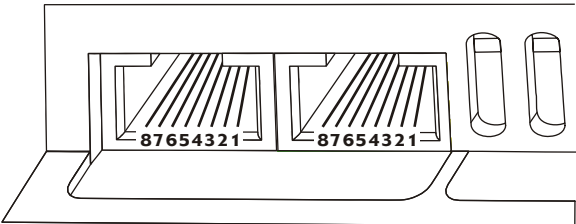

Table 2 – RJ45 sockets and C-Bus pinouts

It is recommended that the Remote Override (On/Off) connections be maintained for correct operation of these services across the C-Bus network, even if they are not intended to be used.

A Clipsal RJ5CB300PL Cat-5 UTP patch cord is included with the unit for easy interconnection. Insert the rubber bungs into any unused RJ45 connectors.

## 8.0 Features

### 8.1 Local Override

The local toggle buttons located on the front of the unit toggle each channel on and off, providing local override capability. Each button illuminates when its respective channel is in the on state (refer to Channel Indicators on Page 14). Local toggle buttons perform different functions depending on how they are pressed. This is summarised in Table 3.

Operation	Function
Quick-press	A single quick-press toggles the state of a channel
Double quick-press	Two quick-presses in quick succession return the channel to the C-Bus network level
Long press	Pressing any of the local toggle buttons for 1 second or more returns all channels to the C-Bus network level

Table 3 – Local toggle button functions

Note that double quick-press and long press operations only apply when the unit/channel is in local override mode. C-Bus commands received by the unit will (by default) override local toggle changes. In this case, only the channel associated with the received commands will revert to the current C-Bus network state. This option may be disabled in software. Refer to Section 9.0, Priority of Operating Modes.

### 8.2 Remote Override

Remote control of all channels on a unit can be achieved via the extra pairs of conductors on the C-Bus connector. Figure 4 illustrates how switches may be connected to these conductors. Green + green & white conductors are used for the Remote ON function. Brown + brown & white are used for Remote OFF. The Remote Override is triggered by connecting the relevant conductors to C-Bus negative. A Clipsal 30/1/2LM mechanism makes an ideal remote input switch.

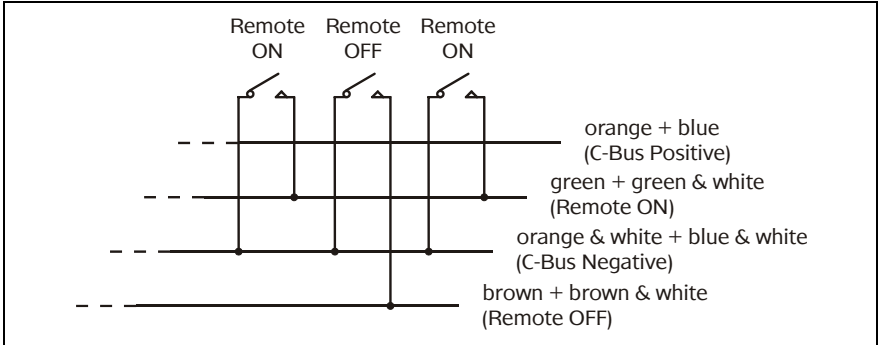

Figure 4 – Remote Override connections



C-Bus is a balanced network and therefore at any point where C-Bus negative (-) is taken, C-Bus positive (+) must also be present. For this reason both conductor pairs must be looped through all remote input switches on the network.

### 8.3 Thermal Monitoring

C-Bus DIN Rail Universal Dimmers incorporate a thermal monitoring protective mechanism. This reduces the load brightness under conditions of inadequate ventilation or excessive ambient temperature.

### 8.4 Short Circuit Cut-out

Each channel of the L5504D2U and L5504D2UP includes short circuit cut-out protection against installation wiring faults, incandescent lamp filament failure, and excessive loading. If a cut-out condition occurs, the channel is automatically reset if the circuit/overload is cleared within a few seconds – otherwise the channel is latched off, and a reset occurs once a channel is toggled OFF and ON.

### 8.5 Soft Turn On

When a channel is switched ON in conventional devices, an abrupt change in brightness occurs. The C-Bus DIN Rail Universal Dimmer produces a soft more gradual brightness change, reducing transient EMI levels and lamp start-up current. This is referred to as “Soft Turn On”.

## 9.0 Priority of Operating Modes

The output status of a C-Bus DIN Rail Universal Dimmer can be changed by:

- pressing a C-Bus button
- activating any of the local toggle buttons (local override)
- using the Remote Override facility.

Table 4 shows the priority ranking of these actions.

Mode	Priority	Function
Thermal overload	1 (highest)	Channel automatically dimmed
Remote OFF	2	All channels off
Remote ON	3	All channels on
Local override	4*	Toggles the channel
C-Bus input unit (Neo, PIR , etc.)	5* (lowest)	Controls the channel

Table 4 – Control priority ranking

\*Using local toggle buttons overrides the normal C-Bus commands such as those issued by input units. By default, once a channel is in local override mode, further relevant C-Bus commands issued by input and control units will override the local override state. This feature can be disabled in software so that all relevant C-Bus commands are ignored by the unit when it is in local override mode.

Further information about programming C-Bus units is provided at the Clipsal Integrated Systems web site (<http://www.clipsal.com/cis>).

## 10.0 Status Indicators

### 10.1 C-Bus Indicator

The “C-Bus” indicator shows the status of the C-Bus network at the unit. If sufficient network voltage and a valid C-Bus clock signal are present, the indicator illuminates (as a continuous green light). If a network is connected which has a higher current load than the power supplies support, the indicator flashes to show a marginal network voltage. If no C-Bus clock is present, or if the unit is powered by C-Bus only (for stand-alone programming), the indicator remains off.

Indicator Status	Meaning
On	Power is on and the network is functional
Flashing	The network voltage is marginal (15 V < voltage < 20 V)
Off	No C-Bus clock signal is present and/or mains power is not connected

Table 5 – The “C-Bus” indicator

Further debugging of possible network problems can be achieved using the Clipsal C-Bus Network Analyser tool (5100NA).

### 10.2 Unit Indicator

The “Unit” indicator shows the status of the individual unit. When mains power is supplied, the indicator illuminates (as a continuous green light). If a local toggle button has been used to perform a local override, or if a Remote Override is active, the indicator flashes with a 90% duty cycle. The Unit indicator does not function when the unit is powered by C-Bus only (for stand-alone programming).

Indicator Status	Meaning
On	Normal operation
Flashing	Unit is in override mode
Off	No mains power is connected

Table 6 – The “Unit” indicator

### 10.3 Channel Indicators

Each dimmer channel has an associated indicator to display its operating condition. The status of this indicator is listed in Table 7.

Indicator Status	Meaning
Off	Channel off
On (green)	Channel on (leading edge mode)
On (orange)	Channel on (trailing edge mode)
Flashing (green)	No load or mains supply to channel
Flashing (orange)	Thermal overload of channel
Flashing (green & orange)	Short circuit cut-out of channel

Table 7 – Individual channel indicators

## 11.0 C-Bus System Clock

C-Bus DIN Rail Universal Dimmers incorporate a software selectable C-Bus system clock. The system clock is used to synchronise data communication over a C-Bus network. At least one active C-Bus system clock is required on each C-Bus network for successful communication. No more than three units on any C-Bus network should have clock circuitry enabled, so this option is normally disabled using the C-Bus Toolkit software.

If a system clock is required, it can be enabled from the unit’s “Global” tab in the C-Bus Toolkit software.

## 12.0 C-Bus Network Burden

C-Bus DIN Rail Universal Dimmers incorporate a software selectable network burden. The network burden can be enabled from the unit’s “Global” tab in the C-Bus Toolkit software, but only if the C-Bus system clock is enabled, and the Unit Address is set to 001.

One network burden is normally required to ensure correct operation of each C-Bus network. The Network window of a C-Bus Toolkit project provides a summary of a C-Bus network according to the units added to the Database. This can be helpful in determining whether or not a burden is required on a particular network.



Disable the network burden on all 5100PC Interface units before installing C-Bus DIN range products which include a power supply. (The 5100PC is a superseded non-DIN rail unit). If a burden is required, use the built-in burden on the DIN rail unit only.

## 13.0 Power-Up Load Status

C-Bus output units have on-board non-volatile memory, which is used to store the operating state of the unit in case of power loss. On restoration of power, L5504D2U and L5504D2UP products initiate a power-up diagnostic routine, which lasts approximately 5 seconds. Channels are then restored according to their previous states, and according to the unit's recovery settings.

## 14.0 C-Bus Power Requirements

C-Bus DIN Rail Universal Dimmers draw 18 mA from the C-Bus network when mains power is not connected, but draw no current from the network when mains is present.

In addition, the L5504D2U supplies up to 200 mA to the network when connected to the mains. The L5504D2UP does not include a C-Bus power supply.

Adequate C-Bus Power Supply Units must be installed to support connected devices. The Network window of a C-Bus Toolkit project provides a summary of a C-Bus network according to the units added to the Database. This can be helpful in determining the power supply requirements of a particular network.

## **15.0 Power Surges**

Each unit incorporates transient protection circuitry. Additional external power surge protection devices should be used to enhance system immunity to power surges. It is strongly recommended that overvoltage equipment such as the Clipsal 970 be installed at the switchboard.

## **16.0 Megger Testing**

Megger testing must never be performed on the C-Bus data cabling or terminals as it could degrade the performance of the network.

Megger testing of a mains electrical installation that has C-Bus units connected will not damage the units. Since C-Bus units contain electronic components, this should be taken into account when interpreting megger readings.

## **17.0 Programming**

As with other C-Bus units, a C-Bus DIN Rail Universal Dimmer must be programmed before it will function as part of a C-Bus network. This can be accomplished using learn mode. However, using the C-Bus Toolkit software provides a greater level of flexibility and customisation.

Units do not need a mains connection in order to be programmed via the C-Bus Toolkit. They can be connected to any operational C-Bus network that is capable of supporting one or more extra C-Bus units (18 mA current required). Units can then be configured using the Toolkit software. Indicators and relays will only function when a mains connection is established.

The C-Bus Toolkit software can be downloaded from the Clipsal Integrated Systems web site ([www.clipsal.com/cis](http://www.clipsal.com/cis)). Further information about programming C-Bus units is provided at this site.

## 18.0 Electrical Specifications

Parameter	Description	
	L5504D2U	L5504D2UP
Nominal supply voltage	220 to 240 V AC	220 to 240 V AC
Frequency range	47 to 53 Hz	
C-Bus supply voltage	15 to 36 V DC @ 18 mA required for programming when mains is not connected. Supplies 200 mA to the C-Bus network when mains is connected.	15 to 36 V DC @ 18 mA required for programming when mains is not connected. 15 to 36 V DC @ 0 mA required for programming when mains is connected. Does not supply current to the C-Bus network.
C-Bus AC input impedance	50 k $\Omega$ @1 kHz	100 k $\Omega$ @1 kHz
Electrical isolation	3.75 kV RMS from C-Bus to mains	
Max. units per network	10	100
Load rating	Up to 2.5 A per channel (refer to Section 5.0, Page 6)	
Dimmer type	Trailing edge/leading edge phase control (auto selection)	
Compatible loads	Incandescent, halogen, LV lighting (electronic transf.), LV or neon* lighting (iron-core transf.), exhaust fans, ceiling fans.	
Quiescent power	20 W	12 W
Warm up time	5 seconds	
Network clock	Software selectable	
Network burden	Software selectable (Unit Address 001 only)	
Operating temperature	0 to 45 °C (32 to 113 °F)	
Operating humidity	10 to 95% RH	

\* Neon lamps must be used in conjunction with a 2 or 4 Amp MCB and a Clipsal 5100NLA Neon Lighting Adaptor.

## 19.0 Mechanical Specifications

Parameter	Description
Dimensions (W×H×D)	216 × 92 × 63 mm (8.5 × 3.62 × 2.48 inches)
Weight	L5504D2U: 593 g L5504D2UP: 717 g
Mains terminals	Accommodates 2 × 1.5 mm <sup>2</sup> or 1 × 2.5 mm <sup>2</sup> (2 × 16 AWG or 1 × 13 AWG)
C-Bus connections	RJ45 sockets

The L5504D2U and L5504D2UP have the same dimensions. No user serviceable parts inside.

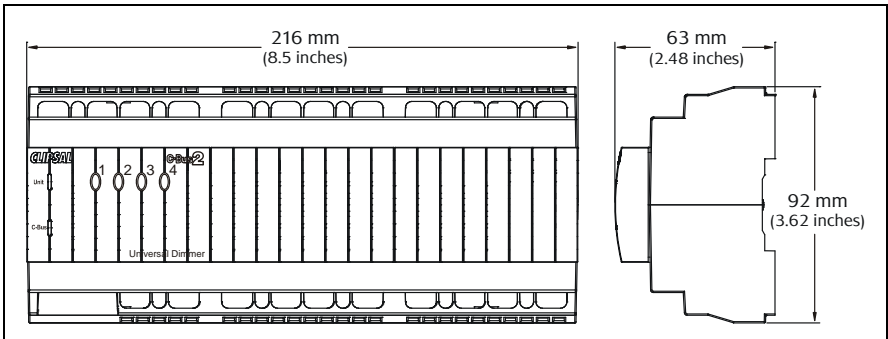

## 20.0 Standards Complied

### DECLARATIONS OF CONFORMITY

#### **Australian/New Zealand EMC & Electrical Safety Frameworks and Standards**

Model L5504D2U and L5504D2UP products comply with the following:



Regulation	Standard	Title
EMC (C-Tick)	AS/NZS 4051	RFI Emissions Standard
Electrical Safety	AS/NZS 3100 AS/NZS 61558-1	General Requirements for Electrical Equipment Safety of Power Supplies and Transformers

#### **European Directives and Standards**

Model L5504D2U and L5504D2UP products comply with the following:



European Council Directive	Standard	Title
EMC Directive 89/336/EEC	EN 60669-2-1 Clause 26.1  EN 60669-2-1 Clause 26.2	Immunity to ESD, RFI, EFT, Surge Voltages, Voltage Dips and Interruptions  RF and Low Frequency Emissions
Low Voltage Directive 73/23/EEC	EN 60669-2-1  EN 61558-1	Switches for Household Fixed Electrical Installations Part 2-1  Safety of Power Supplies and Transformers

#### **Other International Directives and Standards**

Model L5504D2U and L5504D2UP products comply with the following:

Regulation	IEC Standard	Title
EMC	60669-2-1 Clause 26.1 60669-2-1 Clause 26.2	Immunity to ESD, RFI, EFT, Surge Voltages, Voltage Dips and Interruptions RF and Low Frequency Emissions
Electrical Safety	61558-1 60669-2-1	Safety of Power Supplies and Transformers Switches for Household Fixed Electrical Installations Part 2-1



## Technical Support and Troubleshooting

For further assistance in using this product, consult your nearest Clipsal Integrated Systems (CIS) Sales Representative or Technical Support Officer.

Technical Support Contact Numbers	
Australia	1300 722 247 (CIS Technical Support Hotline)
New Zealand	0800 888 219 (CIS Technical Support Hotline)

Technical Support email: [techsupport.cis@clipsal.com.au](mailto:techsupport.cis@clipsal.com.au)

Sales support email: [sales.cis@clipsal.com.au](mailto:sales.cis@clipsal.com.au)

A list of worldwide contacts, additional product information and technical resources is provided at <http://www.clipsal.com/cis/>

## Product of Clipsal Integrated Systems A Division of Clipsal Australia Pty Ltd

ABN 27 007 873 529

### Head Office

12 Park Terrace, Bowden, SA 5007, Australia

Telephone: (+61) 8 8345 9500

Facsimile: (+61) 8 8346 0845

Email: [cis@clipsal.com.au](mailto:cis@clipsal.com.au)

Web: <http://www.clipsal.com/cis/>

1036566