

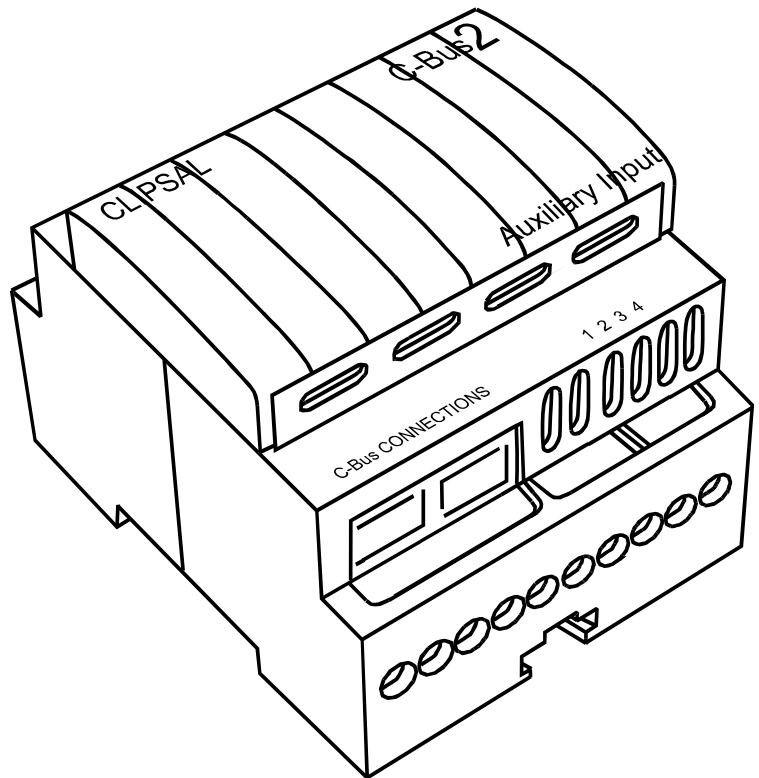

C-Bus Four Channel Auxiliary Input Unit Installation Instructions

5504AUX Series



REGISTERED DESIGN
REGISTERED PATENT



Table of Contents

Section.....	Page
1.0 Product Range	3
2.0 Description	3
3.0 Capabilities.....	3
4.0 Wiring Diagram.....	3
5.0 Connection to the C-Bus Network	4
6.0 Status Indicators.....	5
7.0 C-Bus Power Requirements	5
8.0 Power Surges and Short Circuit Conditions	5
9.0 Megger Testing	5
10.0 Standards Complied	5
11.0 Programming Requirements.....	6
12.0 Important Warning.....	6
13.0 Electrical Specifications.....	7
14.0 Mechanical Specifications	7

Copyright Notice

© Copyright 2002 Clipsal Integrated Systems Pty Ltd. All rights reserved.

Trademarks

- Clipsal is a registered trademark of Gerard Industries Pty Ltd.
 - C-Bus and C-Bus2 are registered trademarks of Clipsal Integrated Systems Pty Ltd.
 - Intelligent Building Series is a registered trademark of Clipsal Integrated Systems Pty Ltd.
- All other logos and trademarks are the property of their respective owners.

Disclaimer

Clipsal Integrated Systems reserves the right to change specifications or designs described in this manual without notice and without obligation.

1.0 Product Range

L5504AUX C-Bus Four Channel Auxiliary Input Unit

2.0 Description

The 5504AUX Series Four Channel Auxiliary Input Unit is a C-Bus device designed to allow the use of voltage free mechanical switches on C-Bus Networks. For ease of installation, 5504AUX Series Units are DIN Rail mounted, measuring 4M (1M = 17.5 +0.5/-0.00 mm) wide. The L5504AUX is a Learn Enabled C-Bus2 device. Units may be programmed using the C-Bus Installation Software v2.3.0 (or higher), or via the C-Bus2 Learn Mode Features.

3.0 Capabilities

The 5504AUX Series C-Bus Four Channel Auxiliary Input Unit facilitates remote access to C-Bus via any dry contact switch mechanism, such as the Clipsal 30M range. In this way the user can match 2000 Series, Standard Range, Heritage Range, Metal Plate or Prestige Series Products with C-Bus. Alternatively reed, pressure, micro or other switches may be used to enhance system flexibility. Being an input device, the unit transmits messages to output devices to control loads. All C-Bus switching commands are available, including on, off, toggle, timer and dimming functions etc. Dimming operations are best achieved using a spring return type switch such as the Clipsal 30MBPR Bell Press mechanism.

The remote switches are electrically isolated from the C-Bus Network by transformers on each channel input, located within the Auxiliary Switch Input Unit. There is no restriction on cable type between remote switches and the 5504AUX unit. Cable runs should be limited in length so the maximum resistance of the cable plus switch does not exceed 1000Ω. Input Channels of the unit may be wired using common return path wiring, to reduce cabling requirements, however they are polarity sensitive (refer to wiring instructions below).

4.0 Wiring Diagram

Wiring diagram, showing individual return paths

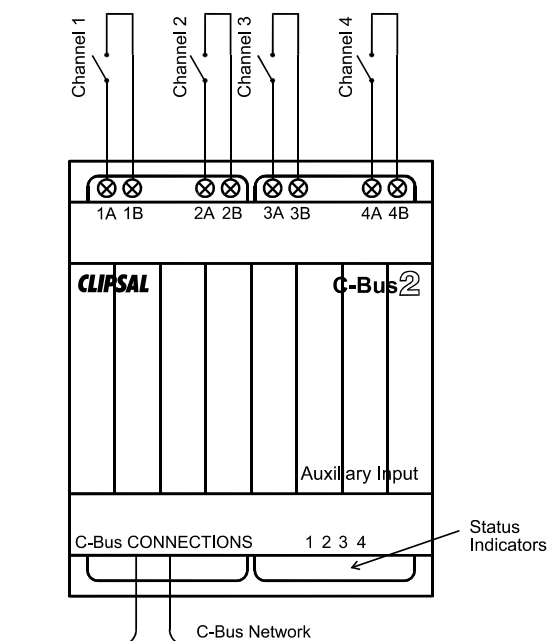

Open collector type switching is allowed with these inputs, however the reference voltage must be earth potential. Connection to mains reference voltages is NOT allowed.

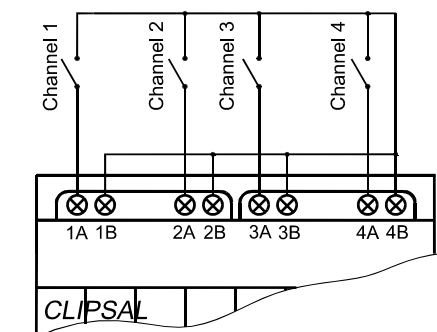

Wiring diagram, showing common return paths

5.0 Connection to the C-Bus Network

Installation requires connection to the unshielded twisted pair (UTP) C-Bus Network Cable.

It is required that Category 5 data cable is used, Clipsal catalogue number 5005C305B.

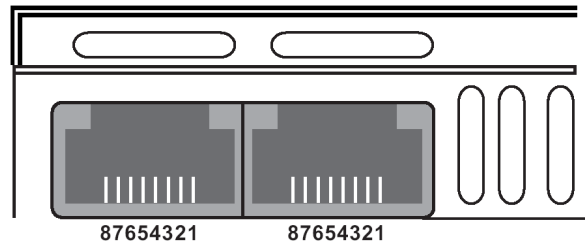

A Clipsal RJ5CB300PL Cat 5 UTP patch cord is included with the 5504AUX for ease of installation. No more than 100 5504AUX Series Units should be connected to one physical C-Bus Network.

RJ Pin	C-Bus Connection	Colour	5504AUX
1	Remote ON	Green/White	Not Connected
2	Remote ON	Green	Not Connected
3	C-Bus Neg (-)	Orange/White	C-Bus Neg (-)
4	C-Bus Pos (+)	Blue	C-Bus Pos (+)
5	C-Bus Neg (-)	Blue/White	C-Bus Neg (-)
6	C-Bus Pos (+)	Orange	C-Bus Pos (+)
7	Remote OFF	Brown/White	Not Connected
8	Remote OFF	Brown	Not Connected

NOTE:

- The 5504AUX does not have Remote Override (On/Off) functions, however these connections must be maintained for correct operation of these services across the C-Bus Network. Override connections are internally connected and looped through the Unit.
- Care must be taken when installing the Auxiliary Input Unit inside a mains rated enclosure. The installer must fix mains cables in the distribution board using cable ties or trunking as required by local wiring rules. All extra low voltage wiring (including C-Bus cable and input wiring for each channel) must be segregated and secured from the mains wiring. Mains rated double insulation is preferred for all Auxiliary Input Unit input channel wiring.
- Rubber bungs are supplied (3 off) for unused RJ45 connectors, to stop foreign bodies from entering the unit. Always ensure these bungs are installed when the Auxiliary Input Unit is to be mounted inside a mains rated enclosure.

6.0 Status Indicators

The 5504AUX Unit incorporates four status indicators (one per channel). Each is intended to indicate the load (Group Address) status. The indicator may also be used to indicate key relationships during C-Bus2 Learn Mode Programming Operations.

Indicator Status	Meaning
On	Load / Group Address is On; Indicator is programmed to be always On; Key involved in C-Bus2 Learn programming operation
Flashing	Timer operation in progress; Key involved in C-Bus2 Learn programming operation (Timer)
Off	Load / Group Address is Off; Indicator is programmed to be always Off; Unit is not powered

7.0 C-Bus Power Requirements

The 5504AUX draws 18mA from the C-Bus Network. Adequate C-Bus Power Supply Units must be installed to support the connected devices. If in doubt, consult the C-Bus Calculator (Network Design Verification Software Utility) before proceeding with the hardware installation.

8.0 Power Surges and Short Circuit Conditions

The 5504AUX is not directly connected to mains, however the mains voltage that is used to supply power to the C-Bus Network must be limited to the range specified. Each unit incorporates transient protection circuitry and additional external power surge protection devices should be used to enhance system immunity to power surges. It is strongly recommended that overvoltage equipment such as the Clipsal 970 be installed at the switchboard.

9.0 Megger Testing

Megger testing must never be performed on the C-Bus data cabling or terminals as it may degrade the performance of the Network.

Megger testing of the mains wiring of an electrical installation that has C-Bus Units connected will not cause any damage to C-Bus Units. Since C-Bus Units contain electronic components, the installer should interpret megger readings with due regard to the nature of the circuit connection.

10.0 Standards Complied

Standard/Directive	Title
AS/NZS 1044:1995 Inc A1, A2; IEC/CISPR14-1:1993 Inc A1, A2 EN55014-1: 2000 Inc. A1; CISPR14-1:2000 Inc. A1	Limits and methods of measurement of radio disturbance characteristics of electrical motor-operated and thermal appliances for household and similar purposes, electric tools and similar electric apparatus
EN61000-3-2:2000; IEC61000-3-2:2000	Electromagnetic Compatibility (EMC) Part 3 Limits Section 2: Limits for Harmonic Current Emissions
EN60669-2-1:2000; IEC60669-2-1:1995 Inc A1, A2	Switches for household and similar fixed electrical installations - Part 2: Particular requirements – Section 1: Electronic switches

11.0 Programming Requirements

The 5504AUX must be programmed to set a unique identification (Unit Address) and the mode of operation on the C-Bus Network. C-Bus Installation Software v2.3.0 (or higher) can be used to configure the:

- Project Name
- Part Name
- Unit Address
- Key / Channel Configurations

The C-Bus Installation Software can be downloaded from the Clipsal Integrated Systems Web Site (www.clipsal.com/cis).

For further information about the programming this and other C-Bus units, please refer to the C-Bus Technical Manual (5000S/2, 5000M/2).

The L5504AUX Auxiliary Input Unit can also be programmed using C-Bus2 Learn Mode. For further information about Learn Mode, please consult the C-Bus2 Learn Mode Operations and Programming Guide.

12.0 Important Warning

The use of any non-approved software in conjunction with the hardware installation without the written consent of Clipsal Integrated Systems may void any warranties applicable to the hardware.

13.0 Electrical Specifications

Catalogue No.	5504AUX Series
C-Bus Supply Voltage	15-36 V _{DC}
Current Drawn	18mA
AC Input Impedance	50kΩ @ 1kHz
Electrical Isolation Rating	500 V RMS C-Bus / Remote Input 500 V RMS Remote Input / Remote Input
Maximum Switch Resistance	1000Ω (including cable resistance)
Contact Voltage	5 V _{DC}
Switch Closed Current	0.4mA
Maximum Number of Units on a Single C-Bus Network	100 Units
C-Bus Unit Type	DINAUX4 L5504AUX
Control Functions	Load Switching, Dimming, Timers, Remote Scene Triggering
Status Indicators	Orange, One Indicator per Channel
Warm-Up Time	5 seconds
C-Bus Input Terminals	2 x RJ45 Sockets
Shipping Weight	130g
Storage Temperature Range	-10 – 60°C
Operating Temperature Range	0 – 45°C
Operating Humidity Range	10 – 95% RH
Dimensions (L x W x H)	72 x 85 x 65mm

14.0 Mechanical Specifications

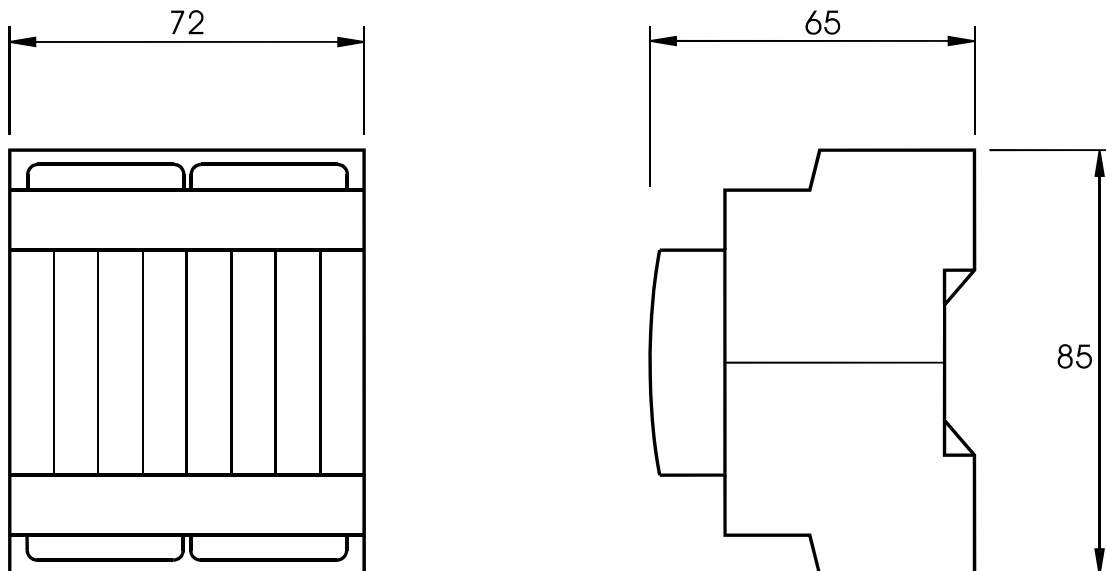

All dimensions are in millimeters.
No user serviceable parts inside.

Further Information

For further information about configuring this product and other C-Bus devices, please consult the documentation supplied. Further assistance can be obtained as follows:

- **C-Bus Manuals**
The 5000M/2 C-Bus Technical Manual provides a comprehensive and definitive guide to Clipsal C-Bus. Includes hardware and software specifications, product datasheets, system design and installation guides, and software overview with fully worked programming examples.
- **C-Bus Installation Software**
The 5000S/2 C-Bus Installation Software (includes 5000M/2 C-Bus Technical Manual) may be used to unlock the power and flexibility of Clipsal C-Bus. Unit operation may be completely customised to suit user requirements. Advanced control functions may be programmed.
- **C-Bus Installer Training Courses**
Contact your nearest Clipsal Integrated Systems Sales or Technical Support Officer and enquire about Clipsal C-Bus Installer Training and Certification Programs today !!
- **Technical Support and Troubleshooting**
For further assistance, please consult your nearest Clipsal Integrated Systems Sales Representative or Technical Support Officer.

Technical Support Hotline	1 300 722 247 (Cost 25¢ per call, Australia Only)
Technical Support Email	techsupport.cis@clipsal.com.au
Sales Support Email	sales.cis@clipsal.com.au
Clipsal Integrated Systems Website	clipsal.com/cis

Products of Clipsal Integrated Systems Pty Ltd

ABN 15 089 444 931

Head Office

12 Park Terrace, Bowden
South Australia 5007

International Phone +61 8 8269 0560

International Fax +61 8 8346 0845

Internet clipsal.com/cis

E-Mail cis@clipsal.com.au

1036391