

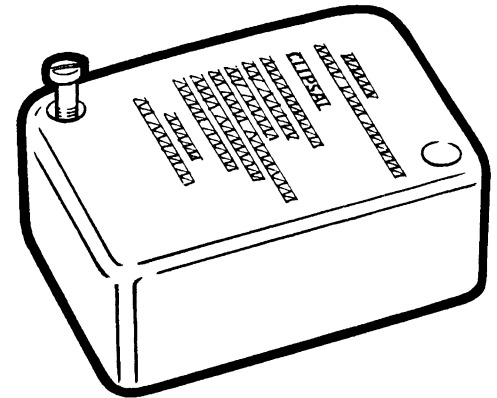

Smoke Alarm Isolation Unit

Installation Instructions

756



Products of Gerard Industries Pty Ltd

ACN 007 873 529

12 Park Terrace, Bowden, South Australia 5007

Telephone (08) 8269 0511

Facsimile (08) 8340 1724

Internet <http://www.clipsal.com.au>

E-Mail plugin@clipsal.com.au



WARRANTY

1. The benefits conferred herein are in addition to, and in no way shall be deemed to derogate; either expressly or by implication, any or all other rights and remedies in respect to this Clipsal Electronic Product, which the consumer has under the Commonwealth Trade Practices Act or any other similar State or Territory Laws.
2. The Warrantor is Gerard Industries Pty Ltd of 12 Park Terrace Bowden, South Australia 5007. Telephone (08) 8269 0511. With registered offices in all Australian States.
NSW 122 Canterbury Road, Padstow 2211. Telephone (02) 9794 9200
VIC 83-89 Queens Parade, North Fitzroy 3068. Telephone (03) 9207 3200. 303 North Street, Albury NSW 2640. Telephone (060) 41 2377.
QLD (Brisbane) 919 Nudgee Road, Nudgee 4014. Telephone (07) 3267 8044. (Townsville) 5-7 Leyland Street, Garbutt 4814. Telephone (077) 25 1822.
WA 23 Truganina Road, Malaga 6062. Telephone (09) 442 4444.
TAS (Launceston) 63 Boland Street, Launceston 7250. Telephone (03) 6331 6951. (Hobart) 55 Lampton Avenue, Derwent Park 7009. Telephone (03) 6272 3177.
NT 16 Albatross Street, Winnellie 0820. Telephone (08) 8947 0278
3. This Clipsal Electronic Product is guaranteed against faulty workmanship and materials for a period of two (2) years from the date of installation.
4. Gerard Industries Pty Ltd reserves the right, at its discretion, to either repair free of parts and labour charges, replace or offer refund in respect to any article found to be faulty due to materials, parts or workmanship.
5. This warranty is expressly subject to the Clipsal Electronic Product being installed, wired, tested, operated and used in accordance with the manufacturer's instructions.
6. All costs of a claim shall be met by Gerard Industries Pty Ltd, however, should the product that is the subject of the claim be found to be in good working order all such costs shall be met by the claimant.
7. When making a claim the consumer shall forward the Clipsal Electrical Product to the nearest office of Gerard Industries Pty Ltd together with adequate particulars of the defect within 28 days of the fault occurring.

The 756 Smoke Alarm Isolation Unit, is a device which connects to the Clipsal Lifesaver® 755 Smoke Alarm and provides a set of isolated normally open (N.O) and normally closed (N.C) change-over contacts permitting auxiliary devices such as sirens, strobes and/or security systems to be enabled when the 755 Smoke Alarm is in the alarm state. The 756 is capable of operating correctly in the absence of mains supply and derives its power from the Smoke Alarm only when the Smoke Alarm is in the alarm state. The 756 may also be used to provide connection of the 755 Smoke Alarm output to the Clipsal C-Bus, Clipsal Room Control System, or Clipsal Minder.

TECHNICAL SPECIFICATIONS

Contacts:	Normally Open (N.O) and Normally Closed (N.C) (change-over contacts).
Contact Rating:	10A resistive and inductive, 250V a.c. 50Hz.
Interconnection Input:	6V to 10V d.c referenced to Neutral.
Supply Current:	Alarm mode - 1mA minimum. Non-alarm mode (standby) - Nil
Maximum number of Smoke Alarms interconnected to a single 756 Isolation Unit:	*40
*Note:- refer to table on page 6 if more than one Isolation Unit is required to be connected.	
Switching Delay: (One only Smoke Alarm)	Turn On - typically **9 seconds on application of Interconnect input voltage. Turn Off - typically 3 seconds on removal of Interconnect input voltage.
**Note:- longer turn on delay times may be experienced depending upon how many Smoke Alarms are interconnected with the Isolation Unit.	
Cables Accommodated:	2 x 2.5mm ² per terminal.
Electrical Safety Isolation:	4kV between input and change over contacts.
Operating Temperature Range:	0°C to 50°C (ambient).

INSTALLATION (For Connection With 755 Smoke Alarms)

The 756 Smoke Alarm Isolation Unit requires only two connections to be made to the Smoke Alarm. These are to the Interconnect and Neutral terminals. A Loop terminal has also been provided on the input side of the Isolation Unit. The Normally Open (N.O) and Normally Closed (N.C) contact terminals may then be wired to an auxiliary device requiring switching/triggering when the Smoke Alarm is activated.

240V a.c. installation must be carried out by a licensed electrician or similarly qualified personnel in accordance with the SAA Wiring Rules (AS3000).

Prior to wiring the 756 Isolation Unit, it is recommended that the electronic circuit board be removed from the enclosure and that the enclosure base be fixed to a suitable mounting surface. This will ensure that the delicate electronic circuitry of the 756 does not become accidentally damaged when mounting the base.

When wiring has been completed, the adhesive tape backing may be removed from the bottom of the electronic circuit board and the board attached to the mounting base. The cover enclosure may then be attached to the mounting base which will in turn secure the internal electronic circuitry and wiring. (Note that it will be necessary to cut out appropriate cable entry holes at either end of the enclosure prior to attaching the cover to the base.)

TESTING

1. Testing may be performed as soon as all of the connections have been made to the 756 Isolation Unit and Smoke Alarm(s).
2. Ensure that the mains is switched off.
3. Check that a fresh 9V battery is fitted to your Smoke Alarm(s). Unless a 9V battery is installed to your Smoke Alarm, disconnection of mains power will render the 756 Isolation Unit inoperative.
4. The Smoke Alarm Isolation Unit may be tested by pressing the HUSH/TEST button on the 755 Smoke Alarm. (Note:- If more than one Smoke Alarm is connected it is recommended that the furthest Smoke Alarm from the Isolation Unit is used for performing this test.) The Smoke Alarm Isolation Unit should activate the device connected to the change-over contact terminals within approximately 9 seconds of the Smoke Alarm siren sounding.
5. Restore mains power to the Smoke Alarm(s) and Isolation Unit and repeat test number 4.
6. It is recommended that the above test be performed at least once a month to ensure that the installation is operating correctly.
7. If the Isolation Unit fails to operate in any of the above tests, check the wiring, 9V battery, fuses or circuit breaker.

- Figure 2 illustrates the wiring diagram for connection of the 756 Isolation Unit to a single 755 Smoke Alarm. For connecting the Isolation Unit to any other type or model of Smoke Alarm please consult your nearest Clipsal representative.

**Fuse or
Circuit
Breaker**

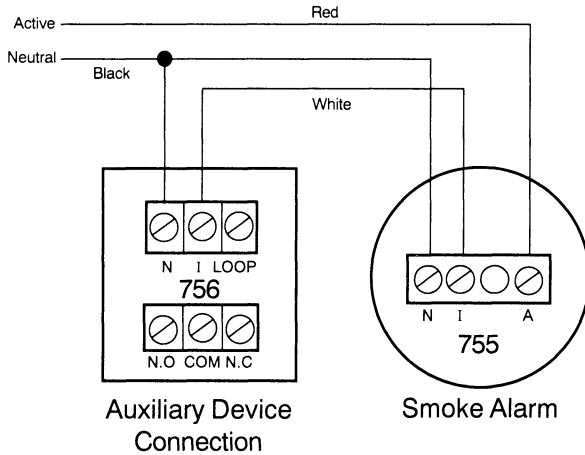

Figure 2
Connection to a single 755 Smoke Alarm

- Figure 3 illustrates the wiring diagram for connection of the 756 Isolation Unit to multiple 755 Smoke Alarms.

**Fuse or
Circuit
Breaker**

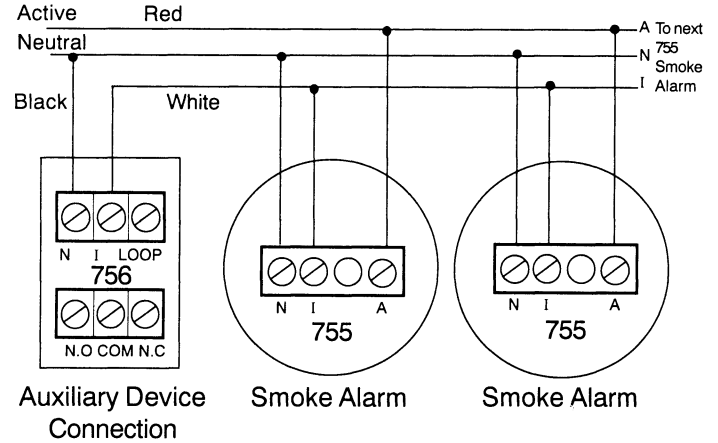

Figure 3
Connection to multiple 755 Smoke Alarms

- The 756 Isolation Unit may be connected to as many as 40 Clipsal Lifesaver 755 Smoke Alarms. If more than one Smoke Alarm Isolation Unit is required to be connected to an installation, refer to the table below which specifies the maximum number of Smoke Alarms that may be connected to the Isolation Units.

No. OF 756 ISOLATION UNITS	No. OF 755 SMOKE ALARMS ALLOWABLE
1	Up to 40
2	Up to 28
3	Up to 16
4	Up to 6

WARNING: Connection of the INTERCONNECT terminal to a 240V Active mains supply will damage the Isolation Unit and void the warranty.

WIRING

- Wiring to the Neutral and Interconnect terminals must be performed using 1.5mm² minimum solid or stranded cable with a rating of 240V.
- Recommended stripping length of cables is 8.5mm.
- Devices connected to the switched output terminals will need to be wired using cables of appropriate colour, insulation thickness and cross sectional area, complying with any technical requirements of the installation and the requirements of any regulatory authority.
- Figure 1 illustrates the internal block diagram for the 756 and highlights the change-over switch contact arrangement.

INPUT SIDE

OUTPUT SIDE

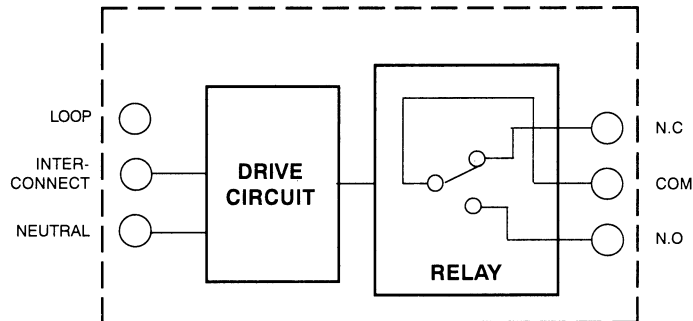

Figure 1
756 Internal block diagram