

15 Warranty

1. The benefits conferred herein are in addition to, and in no way shall be deemed to derogate; either expressly or by implication, any or all other rights and remedies in respect to the Clipsal Product, which the consumer has under the Commonwealth Trade Practices Act or any other similar State or Territory Laws.
2. The warrantor is Clipsal Australia Pty Ltd of 12 Park Terrace Bowden, South Australia 5007. Telephone (08) 8269 0511. With registered offices in all Australian States.
3. This Clipsal Product is guaranteed against faulty workmanship and materials for a period of two (2) years from the date of installation.
4. Clipsal Australia Pty Ltd reserves the right, at its discretion, to either repair free of parts and labour charges, replace or offer refund in respect to any article found to be faulty due to materials, parts or workmanship.
5. This warranty is expressly subject to the Clipsal Product being installed, wired, tested, operated and used in accordance with the manufacturer's instructions.
6. All costs of a claim shall be met by Clipsal Australia Pty Ltd, however should the product that is the subject of the claim be found to be in good working order all such costs shall be met by the claimant.
7. When making a claim the consumer shall forward the Clipsal Product to the nearest office of Clipsal Australia Pty Ltd with adequate particulars of the defect within 28 days of the fault occurring. The product should be returned securely packed, complete with details of the date and place of purchase, description of load, and circumstances of malfunction.

Australian Offices

South Australia

153 Francis Road, Wingfield, 5013 (08) 8268 0400

New South Wales

(Sydney) 122 Canterbury Road, Padstow, 2211 (02) 9794 9200

(Albury) 303 North Street, Albury, 2640 (02) 6041 2377

Victoria

83-89 Queens Parade, North Fitzroy, 3068 (03) 9207 3200

Queensland

(Brisbane) 919 Nudgee Road, Nudgee, 4014 (07) 3274 7444

(Townsville) 736-740 Ingham Road, Mt Louisa, 4814 (07) 4729 3333

Western Australia

23 Truganina Road, Malaga, 6090 (08) 9442 4444

Tasmania

23/34 Innocent Street, Kings Meadows, 7249 (03) 6343 5900

Northern Territory

16 Albatross Street, Winnellie, 0820 (08) 8947 0278

Product of Clipsal Australia Pty Ltd

ABN 27 007 873 529

12 Park Terrace, Bowden, South Australia 5007

Telephone (08) 8269 0511

Facsimile (08) 8340 1724

E-Mail plugin@clipsal.com.au

clipsal.com

Clipsal Australia Pty Ltd reserves the right to change specifications, modify designs and discontinue items without incurring obligation and whilst every effort is made to ensure that descriptions, specifications and other information in this catalogue are correct, no warranty is given in respect thereof and the company shall not be liable for any error therein.

©Copyright Clipsal Australia Pty Ltd 2005. All rights reserved.

10320705

C6-001

CLIPADV/9447

INDOOR INFRASCAN

Passive Infrared Motion Sensors 751 SERIES

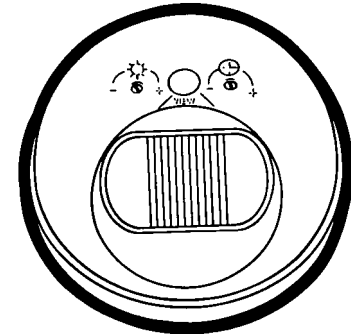

INSTALLATION MANUAL



INFRASCAN
PASSIVE INFRARED SENSOR

Please leave these instructions at the installation site

Contents

Section	Page
1 Product Range	3
2 Description	3
3 Product Selection	3
4 How It Works	4
5 Identification Of Parts	5
6 Installation Location	6
7 Field Of View	6
8 Mounting Procedure.....	7
9 Wiring Diagrams – 751 2 Wire Infrascan	8
10 Wiring Diagrams – 751R 3 Wire Infrascan.....	9
11 Commissioning.....	10
11.1 Set Up For Walk Test	10
11.2 Adjustment Of 'Time-On' and 'Light-Level'	10
12 Troubleshooting.....	11
13 Technical Specifications	12
14 Warning: Using The 751 With Special Loads	14
15 Warranty	16

1 Product Range

- 751** Infrascan Indoor, 240Vac, 50Hz, 2-Wire, 2A, 20 Minute
751R Infrascan Indoor, 240Vac, 50Hz, 3-Wire, 10A, 20 Minute

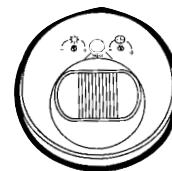

2 Description

Packed with features that have made Clipsal the leader in Passive Infrared (PIR) motion sensor technology, the new 751 Series Indoor Infrascan is next generation of the constantly evolving family of Clipsal PIR sensing devices.

The compact, unobtrusive appearance of the unit, combined with simplified installation and a range of new features, make it the smart light switch for the modern era.

The unit is designed to monitor the immediate environment, and detect people moving within its 'Field of View'. When movement is detected, the unit will activate an electrical load, such as a light, in response to that movement.

Designed, developed and manufactured exclusively in Australia, the unit offers benefits in security, energy management, hospitality and true 'hands-free' switching convenience in a wide range of applications.

3 Product Selection

Be sure to select the appropriate Infrascan product to suit your application:

- The 751 is a 2 wire (does not require neutral connection), but can only switch a limited range of load types.
- The 751R is a 3 wire device (requires neutral connection to operate) capable of switching a wide range of load types.

	Catalogue Number	Neutral Required	Maximum Load*
	751	NO	2A
	751R	YES	10A

* Please refer to Technical Specifications for further information about compatible load types.

4 How It Works

With power applied and a suitable load connected, the Infrascan will be able to detect any moving Infrared source (for example a person) that may intrude upon its 'Field of View'.

The operation of the Infrascan may be set by the user. The unit has two adjustments on the underside of the sensor head for 'Light Level' and 'Time-On' duration.

The 'Light-Level' adjustment activates the load dependent on the ambient light level in the 'Field of View' of the sensor. This adjustment can be set to allow the Infrascan to operate the load at any light level between full daylight and almost complete darkness. For example, the user can ensure the load is only activated when movement is detected at night time. During the day time, when there is adequate natural light, the unit can be set such that it does not activate the load, as it is not necessary to do so.

The 'Time-On' adjustment varies the time span that the load will remain on for after the Infrared source moves out of or stops moving within the 'Field of View'. The load will automatically be switched off after the 'Time-On' period has elapsed. Any period between 5 seconds and approximately 20 minutes may be set by the time adjustment screw.

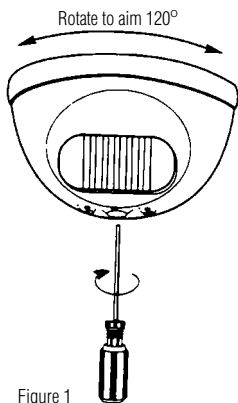

Figure 1

5 Identification Of Parts

84mm mounting centres suit 154, 155, etc.
Std. Ptn mounting accessories

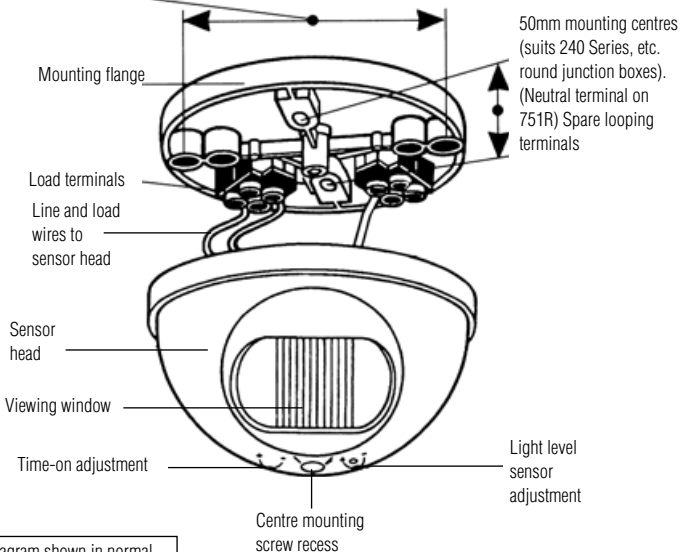

Diagram shown in normal ceiling mount position.

Figure 2

Note:

- The sensor head is specially designed to give optimum performance. Under no circumstances should it be tampered with. There are no user serviceable parts inside.
- Do not apply any pressure on the actual sensor lens itself, as this may damage the lens, and adversely affect the performance of the unit.

6 Installation Location

An Infrascan must be positioned correctly to ensure effective operation. The 'Field of View' is optimum when the sensor head is mounted in a vertical position at a height of 2.4 metres and the 'approach path' is across the face of the sensor.

Note:

- Do not mount the Infrascan close to objects which can create rapid temperature changes eg. air conditioning vents, heater flues, moving water ie. fountains and sprinklers. Avoid locations where condensation is likely to form on the lens.
- Do not mount the Infrascan on any surface that is subject to movement due to wind or other causes.
- In all cases, locate the Infrascan so that the 'approach path' is across the 'Field of View' and not directly towards the Infrascan.

7 Field of view

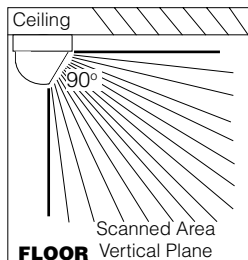

90° Viewing Angle

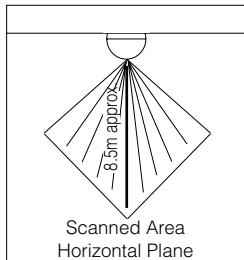

Detection area 6 x 6 metres

Suitable for:

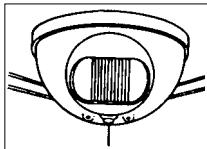

Ceiling Mounting

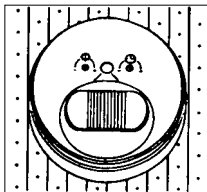

Wall Mounting

Note:

- The absolute range of all PIR Detectors is subject to variation because of daily differences in the background temperature characteristics and type or amount of clothing worn. Rapid and large changes in temperature may be detected even if they appear to be well beyond the stated range.

Note:

- There may be noticeable differences in range due to differing conditions (background temperature, speed of movement, types of clothing worn etc).

8 Mounting Procedure

Step 1:

Fit the Mounting Base in the required location. The unit is suitable for either:

- Ceiling Mount
- Wall Mount

Orient the Base such that the small arrow indicating the Field of View is pointing toward the required detection area.

Step 2:

Terminate incoming wiring on the appropriate terminals as marked. Refer to Section 9, Wiring Diagrams for further information about wiring for different applications.

Line and Load wires to Sensor Head

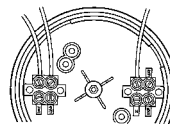

Neutral wire to Sensor Head (751R only)

Step 2
Terminate Wiring

Step 3:

Fit the Sensor Head to the Mounting Base via the single, centrally located mounting located mounting screw (between the 'Time-On' and 'Light-Level' adjustment screws).

Note:

- If leads from the Sensor Head are disconnected from the Terminal Block:
 - 751 Reconnect either lead to the Line terminal and the remaining lead in the Load terminal.
 - 751R Connect brown to Line, white to Load and blue to Neutral terminal.
- Do not fully tighten the screw until the sensor head has been aimed at the area you wish to monitor. The sensor allows up to 120 degrees rotational movement to allow it to be aimed in the required direction.

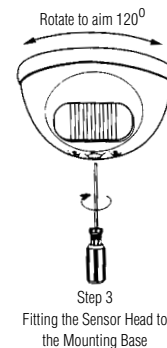
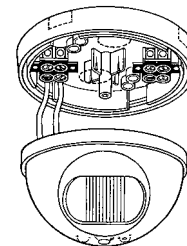
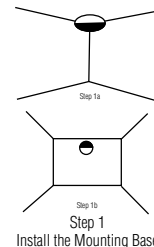

9 Wiring Diagrams – 751 2 Wire Infrascan

1a) Automatic Operation

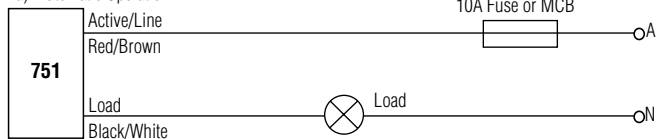

1b) Automatic with manual override ON or OFF

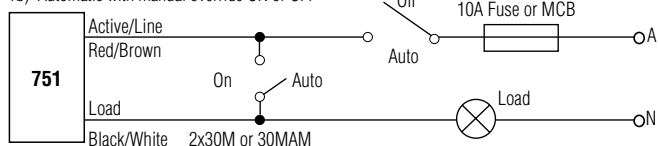

1c) ON, OFF or AUTOMATIC Operation using a 3 position switch

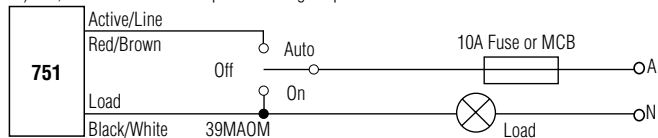

Note:

- When switching to AUTO for any of the above configurations the Infrascan will turn on. Allow 30 seconds plus time-on period for the sensor to stabilise for normal operation. Wiring diagram 1(a), without override switches is preferred as there is no settling period.
- More than one 751 CANNOT be connected in parallel to a common load. If parallel connection of multiple devices to control a common load is required, use Cat. No. 751.



10 Wiring Diagrams – 751R 3 Wire Infrascan

2a) Automatic Operation

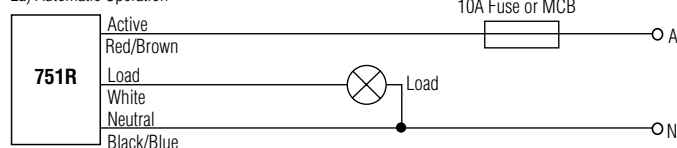

2b) Automatic with manual override ON or OFF

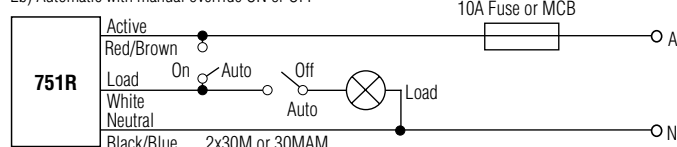

2c) ON, OFF or AUTOMATIC Operation using a 3 position switch

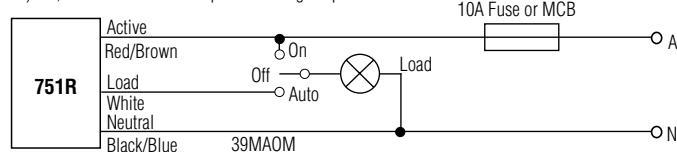

Warning:

- It is illegal for persons other than licensed electricians or persons authorised by legislation to work on fixed wiring of any electrical installation. Penalties for conviction are severe.
- Installation must be carried out in accordance with local wiring rules (AS/NZS3000 Australia and New Zealand).



11 Commissioning

When setting the 'Time-On' or 'Light-Level' adjustments keep clear of the 'Field of View' when assessing the effect of the adjustment.

11.1 Set Up For Walk Test

1	Connect unit to mains power and allow at least 30 seconds for the unit to stabilize before conducting any tests.
2	Set the 'Time-On' adjustment fully anti-clockwise (5 second timer set).
3	Set the 'Light-Level' sensor adjustment fully anti-clockwise (unit set to respond in light or dark conditions).
4	Loosen the centre mounting screw slightly, and aim the sensor head towards the desired 'Field of View'. Tighten the centre mounting screw.
5	Walk slowly around the area in the desired 'Field of View' to confirm the load is activated from within the desired area. - Check that the unit responds appropriately when entering the room. - Check that the unit does not trigger unnecessarily when walking past open entry ways (eg adjoining hallway or corridor). If necessary, re-aim the sensor head.
6	Set the 'Light-Level' as desired for activation at dusk for normal operation.
7	Set the 'Time-On' interval to the desired time for normal operation.



11.2 Adjustment Of 'Time-On' and 'Light-Level' Settings

Time-On adjustment

Adjustment Range: 5 Seconds to 20 Minutes. Rotate clockwise to set required time-out period.

a	Minimum setting (5 seconds).			
b	Set for areas with constant occupation but infrequent movement.			
c	Set for areas with less occupation but constant movement.			

Light-Level adjustment

Adjustment Range: 1 Lux to Full Sunlight.

Rotate clockwise to avoid having load activated when natural light is adequate.

a	To activate the load at dusk, set adjustment to this area.			
b	Load activated at night only.			
c	Load activated both day and night.			

12 Troubleshooting



Problem	Possible Cause	Possible Action
Light turns on for no apparent reason.	Momentary power failure.	None, unit will reset after 'Time-Out'.
	Unseen target.	Check for animals eg dogs/cats etc.
	Extreme draughts of hot and cold air.	Check doors, windows or air conditioning outlets.
	Trees / bushes moving in the wind.	Re-aim sensor head.
Light turns on during daylight.	Vehicle or pedestrian traffic on edge of 'Field of View'.	Re-aim sensor head.
	Wrong setting on 'Light Adjustment'.	Reset according to "Commissioning" Instructions.
Lights do not turn on in dim and dark conditions.	Wrong setting on 'Light Adjustment'.	Reset according to "Commissioning" Instructions.
	Light globe blown.	Replace light globe.
Light remains permanently on.	Manual override switch fitted and set to 'Manual'.	Reset according to "Commissioning" Instructions.
	Moving infrared source being detected. Note: Do not mount to close objects which can change temperature rapidly eg air conditioner vents, heater flues, moving water ie fountains, sprinklers.	Remove unwanted infrared source. If unable to resolve, blank off viewing window. Light should turn off after 'Time-Out'. If light still remains on, call installer.

Note:

- Take care not to scratch or damage the translucent window on the front of the Infrascan as it forms part of the optical detection system. For continued optimum performance ensure that the window is cleaned periodically with mild soap, water and a soft cloth.

13 Technical Specifications

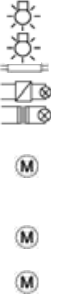
Catalogue Number	751	751R
Operating Voltage	200 – 265V 50Hz a.c.	
Maximum Load Current	2A	10A
Minimum Load (Watts) *	40W	0W
Maximum Off-State Leakage Current	5mA	0mA
Stand-By Power Consumption	< 1W	< 1W
Conductors Required	2 WIRE	3 WIRE
Neutral Required	NO	YES
Operating Temperature Range	0° - 40°C	
Warm-Up Time	30 seconds	
Rated Detection Field at Maximum Sensitivity **	6m x 6m, 8.5m from Sensor Head. Head Rotatable through 120°	
Optimal Mounting Height for Rated Detection Field	2.4 metres	
Timer Delay Range	5 Seconds to 20 Minutes, User Adjustable	
Light Level Inhibit Threshold	Continuous from 1 Lux to Full Sunlight, User Adjustable	
Mounting Surface	Wall or Ceiling Mount (flat surface required)	
Mounting Centres	50mm, 60.3mm, 84mm	
International Protection Rating	IP44	
Overall Dimensions	100mm diameter x 57mm high	
Cables Accommodated	3 terminals, up to 1 x 2.5mm ² cable per terminal	

Catalogue Number	751	751R
Compatible Load Types	 Incandescent 240V Halogen Iron Core Transformers	 Incandescent 240V Halogen Fluorescent Iron Core Transformers Electronic Transformers Shaded Pole Induction Motors (exhaust fans) (8A Max) Split Phase Induction Motors (ceiling fans) (8A Max) Other Motor Loads (Limit to 2A Max)
Incompatible Load Types	 Electronic Transformers Fluorescent Loads Discharge Lamps Motor Loads	N/A
Specifications Typical @ 240Va.c., 25°C		
No user Serviceable Parts Inside		
This product is recommended for INDOOR USE ONLY		

* The 751, 2 Wire Infrascan must be connected to a minimum 40W load, unless the 31CAP (sold separately) is fitted. Failure to do so may cause unexpected or erratic switching of the load.

** The range specifications given are based on a 90kg person travelling at greater than 1 metre per second across the field of view, where there is a temperature differential greater than 5 degrees Celsius between the person and the background. Objects that are hotter or moving faster (eg motor vehicle on nearby roadway) may be detected at greater distances. A person covered in heavy clothing or walking directly towards the sensor may not be detected until they get much closer to the unit.

14 Warning: Using the 751 with Special Loads

Small loads (<40W)

The 751 product can only drive loads greater than 40W. If you wish to drive a smaller load, the 31CAP Load Correction Device is required to be fitted in parallel with the load. For example: when driving a single contactor, be sure to use the 31CAP.

Loads which are sensitive to leakage currents

The 751 is a two wire device. Two wire devices draw their power through the load. If this device is used in conjunction with a load which cannot provide enough continuous load current in the off-state, or the load is sensitive to a high off-state leakage current (for example: relays, contactors, various loads with built-in electronic control etc.) a 31CAP Load Correction Device must be connected in parallel with the load.

Small (non-power factor corrected) fluorescent loads

When a 31CAP is fitted, some small non-power factor corrected fluorescent loads may be controlled using the 751. Success varies from manufacturer to manufacturer. Recommend testing before installation. Installation must be compliant with local wiring rules.

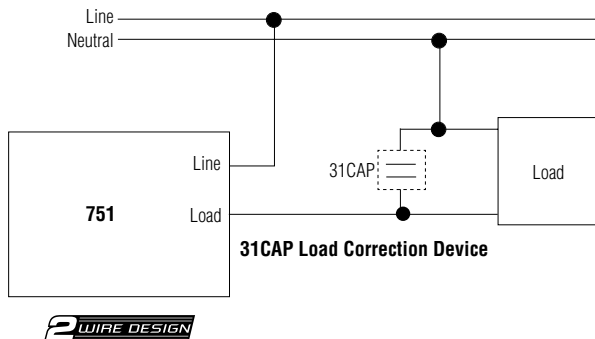

Figure 10

Note:

- Please note the 751R is a three wire device, and switches the load using an internal relay. Power is not drawn through the load and so the 31CAP is not required.